



2009-2011 Precedent Golf Car Owner's Manual

Electric and Gasoline



NOTICE

Warranty information appears at the end of this manual. No other warranties, expressed or implied, are contained herein. Your authorized representative checked the vehicle before it was delivered to you and will provide you a copy of the completed vehicle warranty registration form.

Club Car is not liable for errors in this manual or for incidental or consequential damages that result from the use of the material in this manual.

The two-passenger golf vehicle conforms to the current American National Standards Institute's Z130 Safety and Performance Requirements for Golf Cars. This standard, which promotes safety in the design, application, and operation of golf cars, defines a golf car as "a vehicle used to convey a person or persons and equipment to play the game of golf in an area designated as a golf course." Throughout this manual, the words "golf car" and "vehicle" are used interchangeably.

This manual contains proprietary information that is protected by copyright. All rights are reserved. No part of this manual may be photocopied, reproduced, or translated to another language without the written consent of Club Car, LLC.

The information contained in this document is subject to change without notice.

Club Car reserves the right to make design changes to vehicles without obligation to make these changes on units previously sold.

These vehicles do not conform to Federal Motor Vehicle Safety Standards for automobiles or to FMVSS 500 for low-speed vehicles, and are not equipped for operation on public streets, roads, or highways.

If in English, this manual is the Original Instructions provided by the manufacturer. If in any language other than English, this manual is a translation of the Original Instructions.



P.O. Box 204658
Augusta, Georgia 30917-4658 USA
Telephone 706-863-3000
Service Parts Fax 706-855-7413
www.clubcar.com

Copyright © 2008, 2009, 2010, 2011 Club Car, LLC
Club Car, Tranquility, and ArmorFlex
are registered trademarks of Club Car, LLC
This manual effective August 1, 2008

FOREWORD

Thank you for choosing Club Car, the name most widely recognized as the industry leader in vehicle efficiency and long-lasting value. You have chosen the finest golf car on the market. Please protect your investment and ensure that your Club Car provides years of reliable, superior performance by reading and following the maintenance instructions in this manual.

Your comfort and safety are important to us as well, so we urge you to read and follow the step-by-step operating instructions and safety precautions in this manual. These instructions must be followed in order to avoid the risk of severe personal injury. If you rent or loan your vehicle to others, we recommend that you ask them to read this manual before they operate the vehicle.

Club Car products are backed by a customer support system designed to offer you fast, courteous service. In the event that your golf car needs repairs or service, please contact your local authorized Club Car dealer or distributor, who will be able to provide technical advice, perform warranty work, and sell parts and service manuals. For the name and address of the authorized Club Car dealer or distributor nearest you, logon to our web site at www.clubcar.com or call 1-800-ClubCar (258-2227). If you would prefer to write to us, direct your letter to: Club Car, Attention: Marketing Services, P.O. Box 204658, Augusta, Georgia 30917-4658 USA.

We hope you will consider this owner's manual a permanent part of your golf car. If you sell the vehicle, please include the manual so that the next owner will have the important operating, safety, and maintenance information it contains.

REGULAR MAINTENANCE ITEMS	PERIODIC MAINTENANCE ITEMS
Engine Oil Filter (286 cc and 351 cc) CC P/N 1016467	Spark Plug O.H.V. (286 cc and 351 cc) Either CC P/N AM1232301 or 101881101
Engine Air Filter (286 cc and 351 cc) CC P/N 102558201	Spring Tune-Up Kit CC P/N AM1262501
Engine Fuel Filter (286 cc and 351cc) CC P/N 102003201	Fuse, 10 Amp, Starting Circuit (gasoline vehicle) Fuse under Seat near Solenoid CC P/N 1012295
Battery Terminal Protector Spray CC P/N 1014305	Fuse, 15 Amp, Tow/Run Switch (electric vehicle) Fuse under Seat beneath Electronics Module Cover CC P/N 102538601
Dry Moly Lube CC P/N 1012151	Fuse, 10 Amp, Headlight Circuit (if equipped) Fuse under Seat beneath Electronics Module Cover CC P/N 1012295
Fuse, 0.5 Amp, Brake Light Circuit (if equipped) Fuse under Floor mat beneath Floor Cover Plate CC P/N AM1214301	

TABLE OF CONTENTS

Safety Decal and Feature Identification	4
Practice Safety	10
Proposition 65 – State of California	10
Safety Details	11
General Warnings	11
General Information	16
Model Identification	16
Safety Committee	16
Controls and Indicators – Electric Vehicles	17
Controls and Indicators – Gasoline Vehicles	22
Pre-Operation and Daily Safety Checklist	26
Driving Instructions	28
Towing	30
Transporting on a Trailer	31
Storage – Electric Vehicle	31
Storage – Gasoline Vehicle	33
Maintenance	34
Periodic Service Schedules	35
Periodic Lubrication Schedules	40
Batteries – Electric Vehicles	42
Battery Charger – Electric Vehicles	46
Single Point Watering System (SPWS)	49
Battery – Gasoline Vehicles	51
Engine Oil – Gasoline Vehicles	52
Fueling Instructions – Gasoline Vehicles	55
Cleaning the Vehicle	56
Accessories	56
Subsequent Owner Registration	57
Precedent Four-Passenger Vehicle	57
Vehicle Specifications	59
Warranties	61
EC Declaration of Conformity	65

SAFETY DECAL AND FEATURE IDENTIFICATION

The following pages contain safety decal and feature identification information. For detailed information on specific features, read the appropriate section in this manual.

ELECTRIC PRECEDENT

IMPORTANT NOTICE

This vehicle does not conform to ANSI Z130.1 - "Standard for Golf Cars - Safety and Performance Requirements" because it is capable of speeds in excess of 15 miles per hour. Exercise caution.

CCI 102555901

OPERATING INSTRUCTIONS

- Read owner's manual and dash-mounted safety warnings prior to driving.
- Study and understand controls.

TO OPERATE

- Turn wheels to desired direction and ensure path is clear.
- Turn key to ON position.
- While stopped, place Forward/Reverse switch in desired position: F=Forward N=Neutral R=Reverse (Buzzer will sound)
- Park brake will release and vehicle will start moving when accelerator pedal is pressed.
- Slowly press accelerator pedal to increase speed.
- To stop, release accelerator pedal and press brake pedal.

BEFORE LEAVING

- Press park brake pedal until it locks and holds vehicle.
- Place Forward/Reverse switch in NEUTRAL position.
- Turn key OFF and remove key when not in use.

MOTOR BRAKING

- Electric motor braking provides speed regulation functions.
- For parked vehicle, beeping alarm indicates vehicle roll away.
- In operation, beeping alarm indicates reduction in motor braking.
- Apply brakes to further reduce vehicle speed as required.
- System is activated only when tow switch is in the TOW position.
- When towing this vehicle, tow switch must be in the TOW position.

CCI 102518001

OPERATING INSTRUCTIONS

Before using vehicle, read owner's manual and vehicle safety warnings. Study and understand controls.

TO OPERATE

- Ensure wheels are turned in desired direction and path is clear.
- Turn key to ON position.
- Select FORWARD or REVERSE only when stopped.
- Release park brake fully.
- Vehicle will start moving when accelerator pedal is pressed.
- Slowly press accelerator pedal to increase speed.
- During operation, beeping alarm indicates reduction in motor braking.
- To stop, release accelerator pedal and press brake pedal.

WARNING

Unintended vehicle movement may cause severe injury or death. Before leaving vehicle:

- Engage park brake to lock wheels.
- Place vehicle in NEUTRAL.
- Turn key to OFF and remove key.

103783001

WARNING

ROLLOVER OR FALLING OFF MAY CAUSE SERIOUS INJURY OR DEATH.

- Before using vehicle, read operating instructions.
- Do not start vehicle until all occupants are seated.
- Keep entire body inside vehicle while moving.
- Drive slowly in turns and straight up and down slopes.
- Use brakes to reduce speed when coasting downhill.
- Never operate under the influence of alcohol or drugs.
- For use by authorized persons in designated areas only.
- Remain seated while moving.
- Operate from driver side only.
- Never operate on public roads.
- Hold on to seat handle while moving.
- Two (2) persons per seat maximum.
- Never stand in front of or behind vehicle.
- Do not leave children unattended on vehicle.

CCI 102519301

2011

1	101825101	Decal, On/Off Key Switch (above key switch)	6	Battery Warning Light
2	102518001	Decal, Operating Instructions (on steering wheel)	7	Accelerator Pedal
3	102519301	Decal, Rollover Warning (on instrument panel)	8	Brake Pedal
4	102555901	Decal, Private Speed Notice (below instrument panel) (With Private Speed Notice optional)	9	Park Brake Pedal
5	103783001	Decal, Operating Instructions (on steering wheel)		

ELECTRIC PRECEDENT

⚠ WARNING

BATTERY EXPLOSION COULD RESULT IN SEVERE PERSONAL INJURY

- Place Run/Tow switch in TOW position before performing any of the following:
 - Disconnecting or connecting battery cables
 - Towing this vehicle
 - Extended storage
 - Servicing the vehicle
- Do not store items in battery compartment.
- Keep electronic components dry.
- Do not operate vehicle without this plate properly installed.
- See vehicle service manual before servicing.

RUN

TOW

CCI 103384801

CAUTION EXPOSURE TO WATER MAY DAMAGE ELECTRONIC COMPONENTS

- Do not direct water stream in the area of this plate.
- See vehicle service manual before servicing.

CCI 103384601

⚠ WARNING

SHORTING OF BATTERY TERMINALS CAN CAUSE PERSONAL INJURY OR DEATH.

- When removing component mounting plate, do not place plate directly on top of batteries.

103384701

⚠ WARNING

HEAVY LIFTING CAN CAUSE SEVERE PERSONAL INJURY

- The weight of each 12-volt battery is in excess of 80 lb (36.3 kg).
- Lift batteries only with the aid of an assistant.

CCI 103238501

⚠ DANGER / POISON

HIGH VOLTAGE... RISK OF SHOCK
DO NOT TOUCH UNINSULATED TERMINALS OR CONNECTORS.

NO SPARKS, FLAMES, SMOKING

SULFURIC ACID
CAN CAUSE BLINDNESS OR SEVERE BURNS

SHIELD EYES
EXPLOSIVE GASES
CAN CAUSE BLINDNESS OR INJURY

FLUSH EYES IMMEDIATELY WITH WATER.
GET MEDICAL HELP FAST

SEE INSTALLATION, MAINTENANCE AND OPERATION INSTRUCTIONS
VENTILATE WELL WHEN IN AN ENCLOSED SPACE AND WHEN CHARGING.
KEEP OUT OF REACH OF CHILDREN
DO NOT TIP

CCI 102591901 b

423

1	102591901	Tag, SPWS Battery Warning (on battery watering tubes) (with Single-Point Watering System option)	5	103384801	Decal, Tow/Run Warning
2	103238501	Decal, Battery Weight Warning (On battery bucket, under seat) (vehicles with 12-volt batteries)	6		Tow/Run Switch
3	103384601	Decal, Water Exposure Caution	7		Forward/Reverse Control
4	103384701	Decal, Battery Terminal Warning	8		Battery Charger Receptacle

GASOLINE PRECEDENT

OFF | ON

OPERATING INSTRUCTIONS

- Read owner's manual and safety warnings located on dash panel prior to driving.
- Study and understand controls.

TO OPERATE

- Turn wheels to desired direction and ensure path is clear.
- Turn key to ON position.
- While stopped, place shift lever in desired position:
F—Forward N—Neutral R—Reverse (Buzzer will sound)
- Park brake will release and vehicle will start moving when accelerator pedal is pressed.
- Slowly press accelerator pedal to increase speed.
- To stop, release accelerator pedal and press brake pedal.

BEFORE LEAVING

- Press park brake pedal until it locks and holds vehicle.
- Place Forward/Reverse switch in NEUTRAL position.
- Turn key OFF and remove key when not in use.

CCI 102519301

OPERATING INSTRUCTIONS

Before using vehicle, read owner's manual and vehicle safety warnings. Study and understand controls.

TO OPERATE

- Ensure wheels are turned in desired direction and path is clear.
- Turn key to ON position.
- Select FORWARD or REVERSE only when stopped.
- Release park brake fully.
- Vehicle will start moving when accelerator pedal is pressed.
- Slowly press accelerator pedal to increase speed.
- To stop, release accelerator pedal and press brake pedal.

WARNING

Unintended vehicle movement may cause severe injury or death. Before leaving vehicle:

- Engage park brake to lock wheels.
- Place vehicle in NEUTRAL.
- Turn key to OFF and remove key.

103783002

⚠ WARNING

ROLLOVER OR FALLING OFF MAY CAUSE SERIOUS INJURY OR DEATH.

- Before using vehicle, read operating instructions.
- Do not start vehicle until all occupants are seated.
- Keep entire body inside vehicle while moving.
- Drive slowly in turns and straight up and down slopes.
- Use brakes to reduce speed when coasting downhill.
- Never operate under the influence of alcohol or drugs.
- For use by authorized persons in designated areas only.

- Remain seated while moving.
- Operate from driver side only.
- Never operate on public roads.
- Hold on to seat handle while moving.
- Two (2) persons per seat maximum.
- Never stand in front of or behind vehicle.
- Do not leave children unattended on vehicle.

CCI 102519301

2012

1	101825101	Decal, On/Off Key Switch (above key switch)	5		Low Oil Warning Light
2	102519201	Decal, Operating Instructions (on steering wheel)	6		Accelerator Pedal
3	102519301	Decal, Rollover Warning (on instrument panel)	7		Brake Pedal
4	103783002	Decal, Operating Instructions (on steering wheel)	8		Park Brake Pedal

GASOLINE PRECEDENT

WARNING
BATTERY EXPLOSION / FIRE CAN CAUSE SEVERE INJURY

- Do not contact positive (+) battery post or cable to frame.
- Disconnect negative (-) cable first.
- Negative (-) frame ground.

CCI 102517901

WARNING
CAN CAUSE SEVERE INJURY

Rotating parts

HOT manifold & muffler

KEEP CLEAR

CCI 101960501

WARNING

GASOLINE EXPLOSION / FIRE CAN CAUSE SEVERE INJURY OR DEATH

- No sparks or open flame near fuel or fuel tank.
- No smoking near fuel or fuel tank.
- Stop engine and allow to cool before refueling.
- Turn fuel valve (←) on during operation.
- Turn fuel valve (→) off during storage or transport.

EXCESSIVE SPEED CAN CAUSE SEVERE INJURY OR DEATH

- Do not tamper with engine governor adjustment.

CCI 102517801

295

1	101960501	Decal, Rotating Parts/Hot Manifold Warning (on engine, starter/generator, and transaxle)	4	Choke
2	102517801	Decal, Gas/Governor Warning (on fuel tank hold-down bracket)	5	Forward/Reverse Control
3	102517901	Decal, Frame Ground Warning (on vehicle frame, under seat)		

PRECEDENT VILLAGER 4

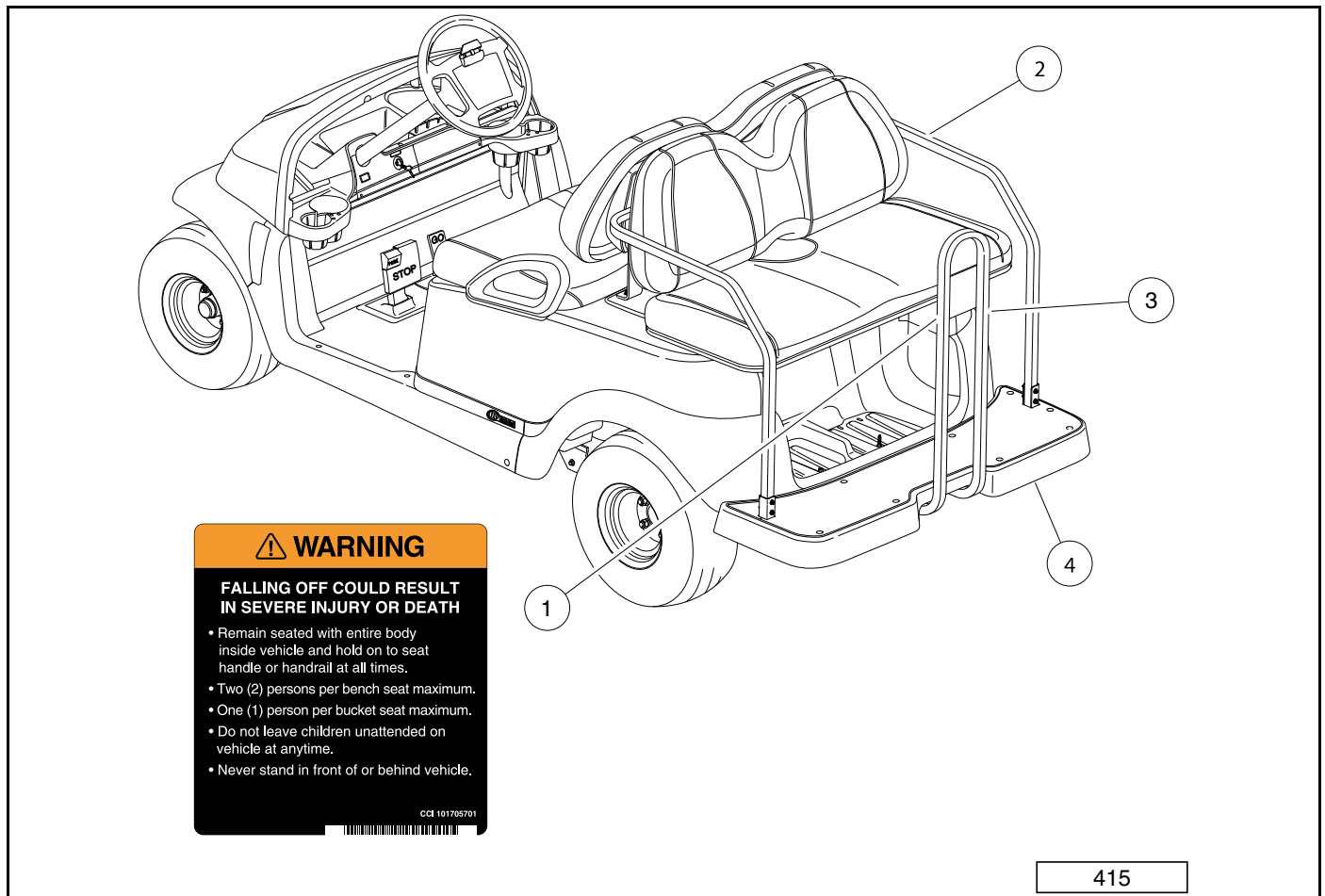

415

1	101705701	Decal, Falling Off Warning (on rear-facing seat hand rail and/or on back side of forward-facing seat backs)	4		Foot rest
2		Hand hold			
3		Hand rail			

PRACTICE SAFETY



399
Figure 1 Practice Safety

Safety signs like you see above may at first seem shocking, but their impact is mild compared with the reality of severe personal injury.

Your safety and satisfaction are of the utmost importance to us. That is why before operating the vehicle, we urge you to review the information in this manual. Understand and become familiar with the DANGER, WARNING, and CAUTION statements and procedures it contains, along with the safety decals that are affixed to your vehicle.

Take time to understand the language of safety. It is a language that can save your life.

PROPOSITION 65 – STATE OF CALIFORNIA

▲ WARNING

- This product contains or emits chemicals or substances that have been determined by the state of California to cause cancer and birth defects or other reproductive harm.

SAFETY DETAILS

WARNING

- **This owner's manual should be read completely before attempting to drive or service the vehicle. Failure to follow the instructions in this manual could result in property damage, severe personal injury, or death.**

It is important to note that some vital statements throughout this manual and on the decals affixed to the vehicle are preceded by the words DANGER, WARNING, or CAUTION. For your protection, we recommend that you take special notice of these safety precautions. Safety precautions are essential and must be followed.

Throughout this manual and on the operation and safety decals affixed to the vehicle, the words "golf car" and "vehicle" are used interchangeably. "Golf car" is defined in the Notice of this manual and no other representation is stated or implied.

If any of the operation or safety decals on the vehicle become damaged, have been removed or cannot be easily read, they should be replaced immediately to avoid possible property damage, personal injury, or death. Contact your distributor/dealer.

DANGER

- **A DANGER indicates an immediate hazard that will result in severe personal injury or death.**

WARNING

- **A WARNING indicates an immediate hazard that could result in severe personal injury or death.**

CAUTION

- **A CAUTION with the safety alert symbol indicates a hazard or unsafe practice that could result in minor personal injury.**

CAUTION

- **A CAUTION without the safety alert symbol indicates a potentially hazardous situation that could result in property damage.**

GENERAL WARNINGS

The following safety statements must be heeded whenever the vehicle is being operated, repaired, or serviced. Vehicle feature identification information is also included. **See Safety Decal and Feature Identification on page 4.** Other specific safety statements appear throughout this manual and on the vehicle.

DANGER

- **Battery – Explosive gases! Do not smoke. Keep sparks and flames away from the vehicle and service area. Ventilate when charging or operating vehicle in an enclosed area. Wear a full face shield and rubber gloves when working on or near batteries.**

DANGER CONTINUED ON NEXT PAGE

DANGER

- Gasoline – Flammable! Explosive! Do not smoke. Keep sparks and flames away from the vehicle and service area. Service only in a well-ventilated area.
- Do not operate engine in an enclosed area without proper ventilation. The engine produces carbon monoxide, which is an odorless, deadly poison.
- The vehicle will not provide protection from lightning, flying objects, or other storm-related hazards. If caught in a storm while driving a Club Car vehicle, exit the vehicle and seek shelter in accordance with applicable safety guidelines for your location.

WARNING

- Follow the procedures exactly as stated in this manual, and heed all DANGER, WARNING, and CAUTION statements in this manual as well as those on the vehicle and battery charger.
- Do not leave children unattended on vehicle.
- Prior to leaving the vehicle unattended or servicing the vehicle, set the park brake, place the Forward/Reverse handle or switch in the NEUTRAL position, turn the key switch to the OFF position, and remove the key. Chock the wheels when servicing the vehicle.
- Improper use of the vehicle or failure to properly maintain it could result in decreased vehicle performance, severe personal injury, or death.
- Any modification or change to the vehicle that affects the electrical system, stability or handling of the vehicle, or increases maximum vehicle speed beyond factory specifications, could result in severe personal injury or death.
- Check the vehicle for proper location of all vehicle safety and operation decals and make sure they are in place and are easy to read. See Safety Decal and Feature Identification on page 4.
- Only trained technicians should service or repair the vehicle or battery charger. Anyone doing even simple repairs or service should have knowledge and experience in electrical and mechanical repair. The appropriate instructions must be used when performing maintenance, service, or accessory installation.
- Wear safety glasses or approved eye protection when servicing the vehicle or battery charger. Wear a full face shield and rubber gloves when working on or near batteries.
- Do not wear loose clothing or jewelry such as rings, watches, chains, etc., when servicing the vehicle or battery charger.
- Use insulated tools when working near batteries or electrical connections. Use extreme caution to avoid shorting of components or wiring.

Electric vehicles only:

- Place Tow/Run switch in the TOW position before disconnecting or connecting the batteries. Failure to heed this warning could result in a battery explosion or severe personal injury.
- To avoid unintentionally starting an electric vehicle, disconnect the batteries and discharge the controller. See Disconnecting the Batteries – Electric Vehicles on page 14.

Gasoline vehicles only:

- To avoid unintentionally starting a gasoline vehicle, disconnect the battery and spark plug wire. See Disconnecting the Battery – Gasoline Vehicles on page 13.
- Frame ground – Do not allow tools or other metal objects to contact frame when disconnecting battery cables or other electrical wiring. Do not allow a positive wire to touch the vehicle frame, engine, or any other metal component.

DISABLING THE VEHICLE

1. Set the park brake.
2. Turn the key switch OFF and remove the key.
3. Place the Forward/Reverse control in the NEUTRAL position.
4. In addition, chock the wheels if servicing or repairing the vehicle.

DISCONNECTING THE BATTERY – GASOLINE VEHICLES

1. Disable the vehicle. **See Disabling the Vehicle on page 13.**
2. Disconnect the battery cables, negative (–) cable first, as shown (**Figure 4**).
3. Disconnect the spark plug wire(s) from the spark plug(s).

CONNECTING THE BATTERY – GASOLINE VEHICLES

1. Connect the battery cables, positive (+) cable first.
2. Tighten battery terminals to 80 in-lb (9 N·m).
3. Coat terminals with Battery Terminal Protector Spray (CC P/N 1014305) to minimize corrosion.
4. Connect the spark plug wire(s) to the spark plug(s).

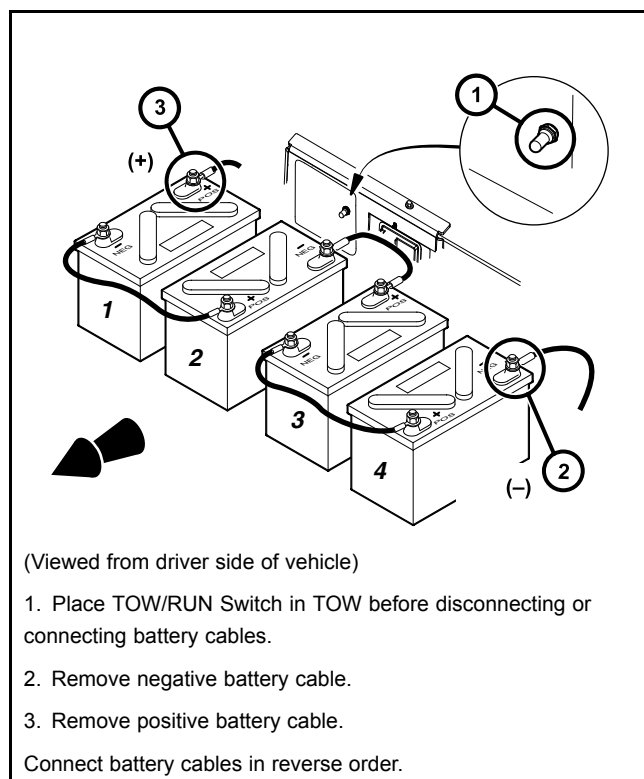

⁴²² **Figure 2 Battery Cable Removal – 4x12-Volt Battery Configuration**

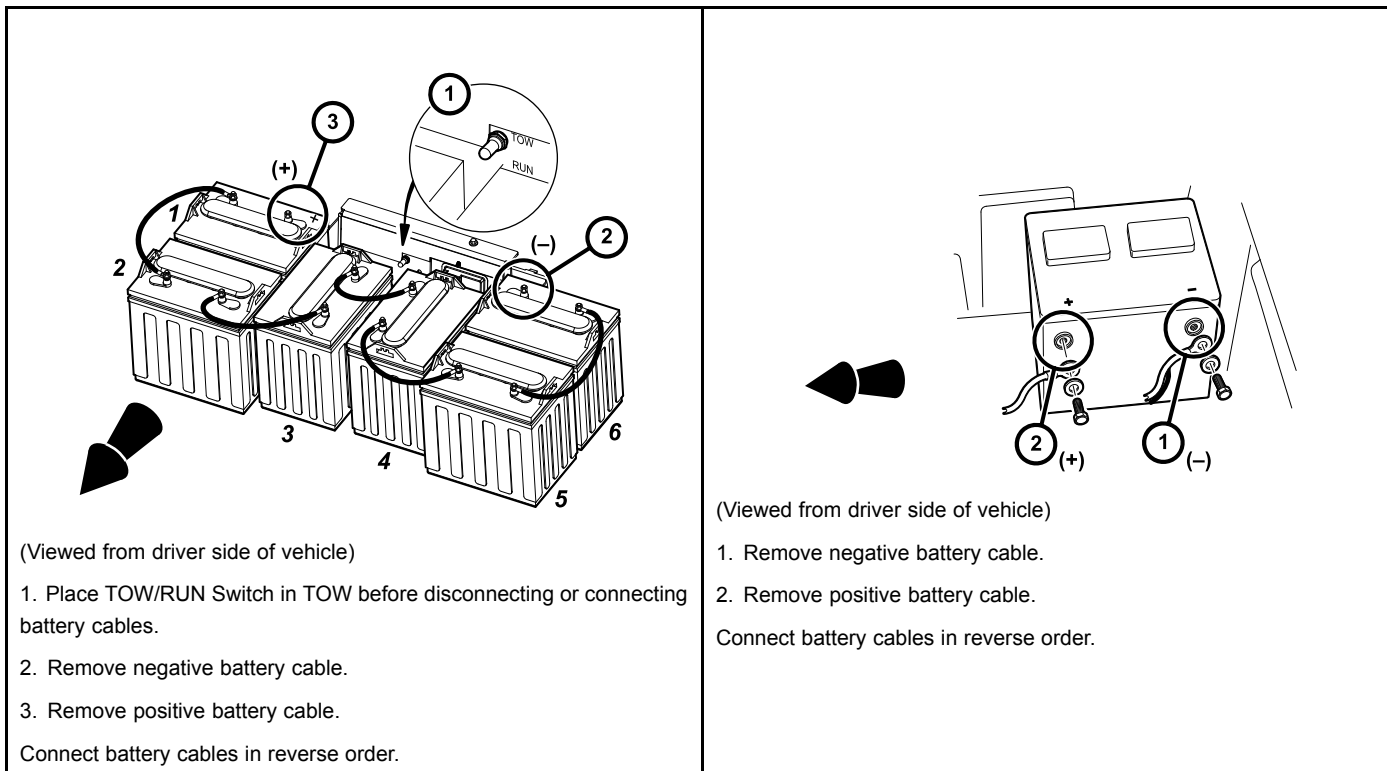

49A **Figure 3 Battery Cable Removal – 6x8-Volt Battery Configuration**

50 **Figure 4 Battery Cable Removal – Gasoline**

DISCONNECTING THE BATTERIES – ELECTRIC VEHICLES

1. Disable the vehicle. **See Disabling the Vehicle on page 13.**
2. Place Tow/Run switch in the TOW position before disconnecting or connecting the batteries. Failure to heed this warning could result in a battery explosion or severe personal injury.
3. Disconnect the batteries, negative (–) cable first, as shown (**Figure 2**) or (**Figure 3**).
4. After disconnecting the batteries, wait 90 seconds for the controller capacitors to discharge.

CONNECTING THE BATTERIES – ELECTRIC VEHICLES

1. Ensure the Tow/Run switch is in the TOW position.
2. Connect the battery cables, positive (+) cable first.
3. Tighten battery terminals to 110 in-lb (12.4 N·m).
4. Coat terminals with Battery Terminal Protector Spray (CC P/N 1014305) to minimize corrosion.

RECYCLING LEAD-ACID BATTERIES

⚠ WARNING

- **Lead-acid batteries contain lead (Pb), other metals, acids and other compounds. If improperly handled, they can contaminate both water and soil, causing environmental damage and personal injury.**

Lead-acid batteries are identified by the symbol shown below and should be properly recycled (**Figure 5**). They cannot be disposed as municipal waste and must be collected separately. Responsibility for environmental protection must be shared, not only by the manufacturers of the batteries, but by people who use the batteries as well. Please contact your nearest Club Car dealer or distributor for information on how to properly recycle your batteries.

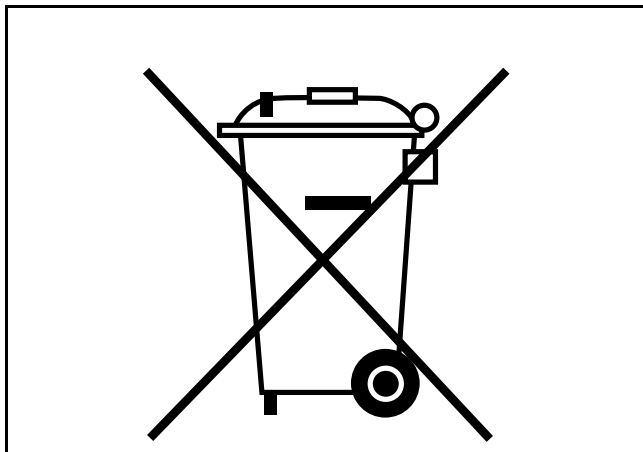

1403 **Figure 5 Dispose of Lead-acid Batteries Properly**

INTERNATIONAL SAFETY SYMBOLS ON BATTERIES

Anyone using, repairing, or servicing the vehicle must understand and heed the safety symbols on the vehicle battery or batteries.

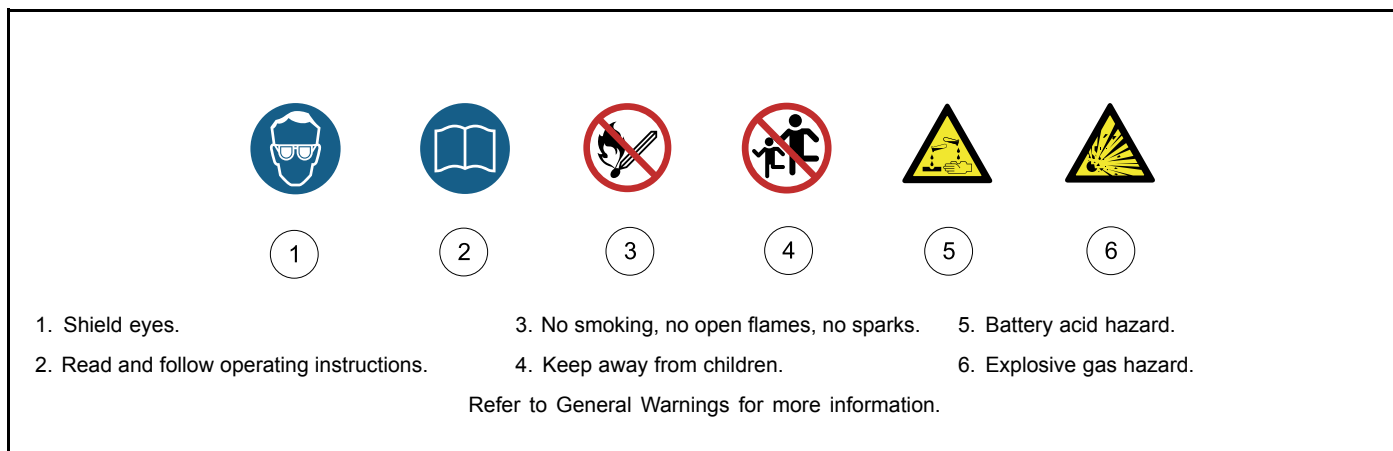

1642 **Figure 6 International Safety Symbols on Batteries**

GENERAL INFORMATION

Precedent Golf Cars are available with either electric or gasoline power. Throughout this manual, important features unique to each model are highlighted. We urge the owner/operator to read and understand this manual, and to pay special attention to the features specific to his/her vehicle(s).

MODEL IDENTIFICATION

The serial number of each vehicle is printed on a bar code decal mounted either below the passenger side cup holder or above the accelerator or brake pedal (Example: PH0901-583947) (**Figure 7**).

The two letters (1) at the beginning of the serial number indicate the vehicle model. The following four digits (2) indicate the model year and production week during which the vehicle was built. The six digits (3) following the hyphen represent the unique sequential number assigned to each vehicle built within a given model year. **See following NOTE.**

NOTE: Have the vehicle serial number available when ordering parts or making inquiries.



1400

Figure 7 Serial Number Decal

SAFETY COMMITTEE

If the golf car is to be rented or is part of a fleet, we strongly recommend that a safety committee be appointed. One of the main concerns of this committee should be the safe operation of the golf cars. This should include at a minimum:

- Where golf cars should be driven.
- Ensuring that proper warnings of driving hazards are displayed and visible.
- Who should and who should not drive golf cars.
- Instructing first time drivers.
- Maintaining golf cars in a safe driving condition.
- How various rules are to be enforced.

The safety committee should include all these items and such others as the committee feels necessary or appropriate.

CONTROLS AND INDICATORS – ELECTRIC VEHICLES

See General Warnings on page 11.

▲ WARNING

- If renting or loaning the vehicle, make sure the driver is familiar with all controls and operating procedures before allowing the vehicle to be driven.
- Do not shift the Forward/Reverse switch while the vehicle is moving. To avoid injury to an unsuspecting passenger or damage to the vehicle, always bring the vehicle to a full stop before shifting the Forward/Reverse switch.
- Release the accelerator pedal and then press the brake pedal firmly until the vehicle stops. To avoid unintentionally starting or rolling the vehicle, set the park brake, place the Forward/Reverse switch in the NEUTRAL position, turn the key switch to the OFF position, and remove the key when leaving the vehicle.

KEY SWITCH

The key switch is mounted on the dash to the right of the steering column (**Figure 8**). It has two positions, OFF and ON, which are clearly labeled. **See following NOTE.**

NOTE: When the key is turned to the OFF position, the main vehicle systems are disabled. The key switch may be used as an emergency stop.

The key can be removed only when the key switch is in the OFF position.

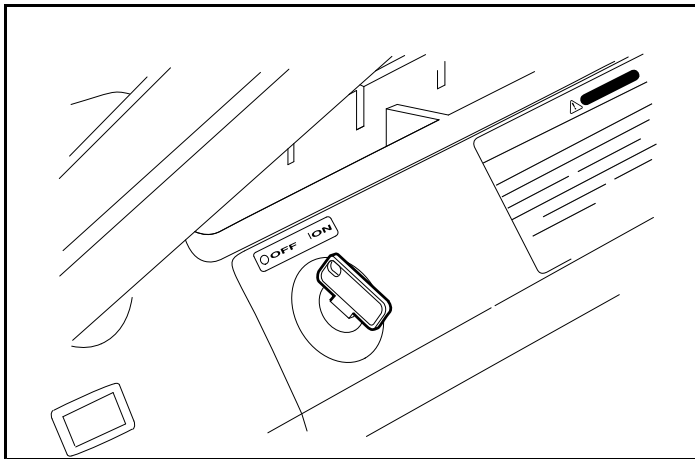

52

Figure 8 Key Switch

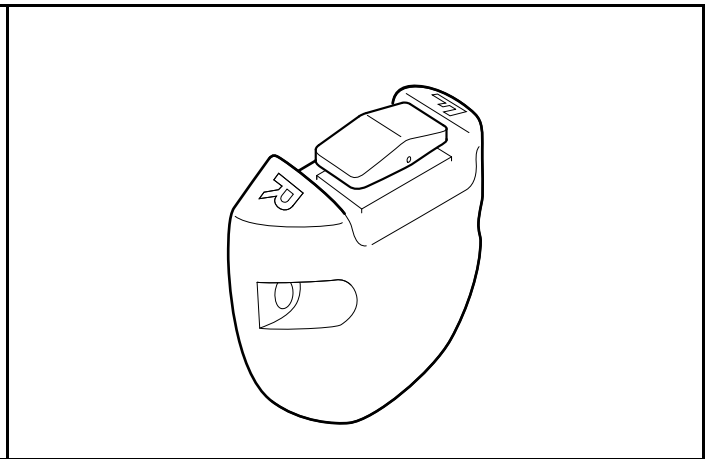

6

Figure 9 Forward/Reverse Rocker Switch – Electric Vehicle

FORWARD/REVERSE CONTROL

The Forward/Reverse rocker switch is located on the seat support panel, below and to the right of the driver's right knee (**Figure 9**). The F (FORWARD) and R (REVERSE) are clearly marked. Push down the FORWARD side of the switch to operate the vehicle in the forward direction, or push down the REVERSE side of the switch to operate the vehicle in reverse. When the rocker switch is positioned in the NEUTRAL position, with neither side down, the

vehicle will not operate if the accelerator pedal is pressed. The reverse buzzer will sound as a warning when the Forward/Reverse switch is in the REVERSE position.

ACCELERATOR PEDAL

The accelerator pedal is the pedal on the right, with the word GO molded into it (**Figure 10**). The operation of the accelerator pedal differs from that of an automobile. When the key switch is the ON position, and the Forward/Reverse switch is in either the FORWARD or REVERSE position, pressing the accelerator pedal will automatically release the park brake and start the vehicle moving in the direction selected (forward or reverse). As the accelerator pedal is pressed, speed will increase until full speed is reached. When the accelerator is released, power will be cut off and the motor will stop running.

Electric vehicles use a special electrical system, which employs motor braking in some modes of operation. In those modes, the vehicle operates as follows:

- **Walk Away Braking:** This feature prevents the vehicle from rolling away uncontrolled should the driver park on a slope and leave the vehicle without locking the park brake. The vehicle will roll at about 1 mph (1.6 km/h). If the walk away braking function remains engaged for two seconds or more, a warning buzzer will sound to alert the driver that motor braking has been activated. **See following WARNING.**

WARNING

- **Walk away braking will not limit vehicle speed to 1 mph (1.6 km/h) on very steep grades. Do not operate vehicle on slopes exceeding 20% grades.**

Excel System Vehicles

- **Motor Braking:** This feature helps to control vehicle downhill speed. When traveling downhill, motor braking engages to maintain speeds proportional to the accelerator pedal position. For example, when the accelerator is fully pressed, motor braking holds the vehicle at the programmed top speed. When the accelerator pedal is fully released, motor braking slows the vehicle to a complete stop or allows the vehicle to coast freely, depending upon the selected controller setting. This feature is selectable. Contact your local Club Car dealer/distributor to inquire about this feature. **See following WARNING.**

WARNING

- **When batteries are fully charged, a warning buzzer will sound during motor braking to alert the driver that motor braking is operating at a reduced level of performance. When this occurs, use the brake pedal to control vehicle speed.**

IQ System Vehicles

- **Pedal Up Motor Braking:** When vehicle speed is above 11 mph (17.7 km/h), releasing the accelerator pedal will activate motor braking, which slows the vehicle speed. Once vehicle speed slows to below approximately 11 mph (17.7 km/h), with the accelerator pedal still released, motor braking will be deactivated and the vehicle will coast freely. This feature is selectable. Contact your dealer/distributor to inquire about this selectable feature. **See preceding WARNING.**
- **Pedal Down Motor Braking:** This feature helps to control vehicle downhill speed. Motor braking is activated when the vehicle reaches the programmed top speed and holds the vehicle at that speed. Motor braking is automatically disengaged when vehicle speed slows below the programmed top speed. **See preceding WARNING.**

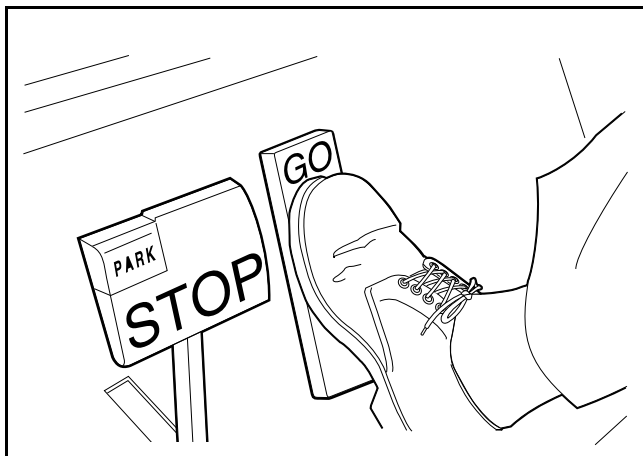

77

Figure 10 Accelerator Pedal

BRAKE PEDAL

The brake pedal is the large pedal on the left with the word STOP molded into it. To slow or stop the vehicle, press the brake pedal with your foot (Figure 11).

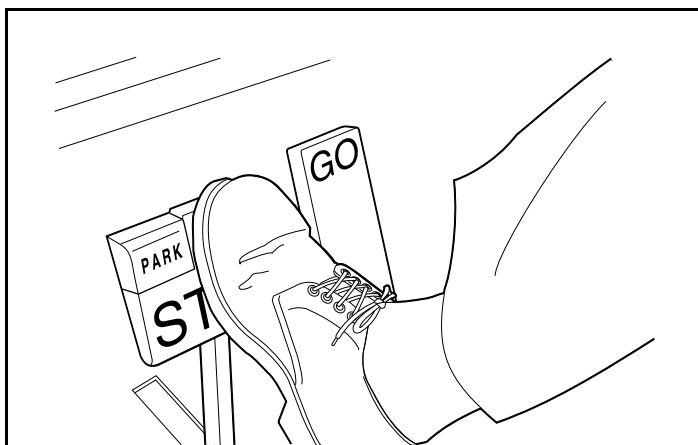

78

Figure 11 Brake Pedal

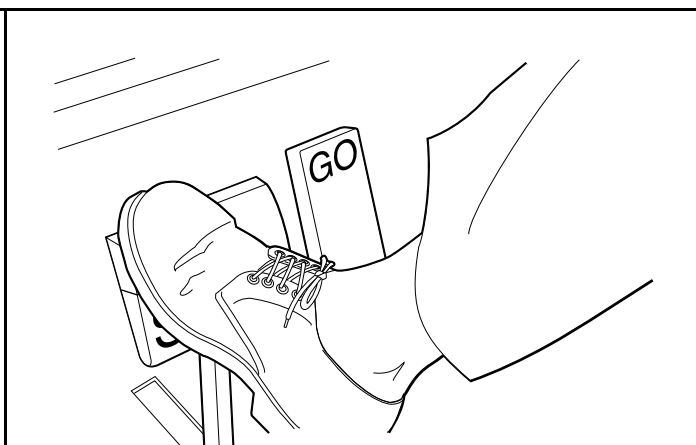

79

Figure 12 Park Brake Pedal

PARK BRAKE PEDAL

The park brake pedal is the small raised portion in the upper left corner of the brake pedal. It has the word PARK molded into it. To set the park brake, press the brake pedal firmly and tilt the park brake portion of the pedal forward with your foot (Figure 12). See following **WARNING** and **NOTE**.

⚠ WARNING

- The park brake will release automatically when either the accelerator or brake pedal is pressed. The park brake has multiple locking positions and should be firmly pressed and locked to prevent the vehicle from rolling.

BATTERY WARNING LIGHT

Precedent electric vehicles feature a dash-mounted warning light (below the steering column) that, when the vehicle is in operation, indicates low battery voltage or, when the vehicle is being charged, indicates a charging problem (**Figure 13**). The battery warning light is controlled by the onboard computer.

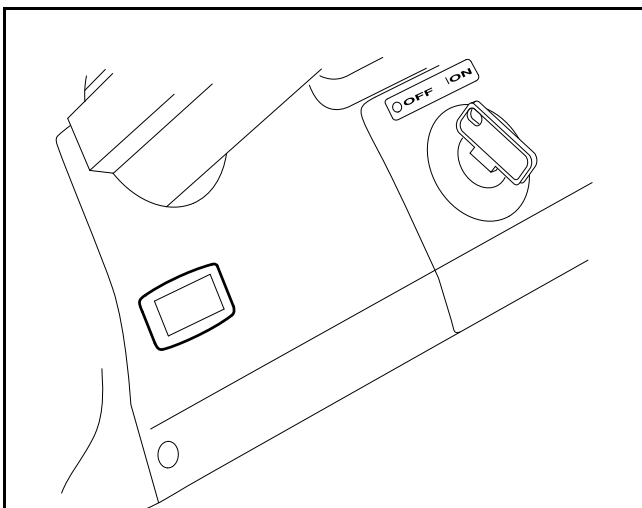

56

Figure 13 Battery Warning Light

When the vehicle is in operation, the warning light is controlled by the onboard computer.

- Batteries' voltage drops below 48 volts when there is no load on the batteries (the vehicle is stopped and there are no accessories on).
- Batteries have discharged to less than 25% of rated capacity.

If the warning light illuminates when the vehicle is operating, there will be enough power remaining to drive the vehicle for approximately 30 minutes. However, the vehicle should be charged at the first opportunity. If the warning light illuminates and the vehicle is unable to operate for 30 minutes, have your Club Car distributor/dealer check the vehicle for a possible battery or electrical system problem.

When the batteries receive an incomplete charge because 1) the DC power cord is disconnected, 2) AC power to the charger is interrupted, 3) automatic charger shut-off occurs after 16 hours of operation, 4) the charger malfunctions, or 5) the wrong charger is used, the warning light will indicate as follows:

- The warning light will not illuminate if the charge is 90% or more complete. The onboard computer will retain in memory the amount of charge needed to fully replenish the batteries and will complete the charge during the next charge cycle.
- When the charger is unplugged, the warning light will illuminate and remain illuminated for 10 seconds if the charge is less than 90% complete but the vehicle has enough power for approximately 30 minutes of operation. This will alert the operator that the vehicle may be used, but that it must be charged to completion as soon as possible.

- The warning light will repeatedly illuminate for 10 seconds, with 4 second intervals if the charger times out at 16 hours and the batteries are not sufficiently charged. This indicates an abnormal charge cycle. The charger and batteries should be checked by your Club Car distributor/dealer.
- The warning light will repeatedly illuminate for 10 seconds, with 4 second intervals during a charge cycle (DC plug is still connected) if AC power to the charger is interrupted. The light will go out when AC power is restored.

LED Light: In addition to the warning light, there is an infrared LED in the dash light assembly, which transmits an infrared signal from the onboard computer (OBC). This signal is received by the optional Communication Display Module, which provides information on the condition of the vehicle and batteries.

TOW/RUN SWITCH

▲ WARNING

- Place Tow/Run switch in the TOW position before disconnecting or connecting the batteries. Failure to heed this warning could result in a battery explosion or severe personal injury.
- When the Tow/Run switch is in the TOW position, all motor braking functions, including walk away braking, are disabled.

The Precedent electric vehicles are equipped with a Tow/Run switch, located under the seat behind the batteries (**Figure 14**). The switch must be in the RUN position in order to operate the vehicle. When the switch is in the TOW position, power to the vehicle electrical components is turned off and the vehicle will not operate. **See following NOTE.**

NOTE: After placing the Tow/Run switch in the TOW position, allow 10 seconds to elapse before switching back to the RUN position.

After placing the Tow/Run switch in the RUN position, allow 10 seconds to elapse before operating the vehicle.

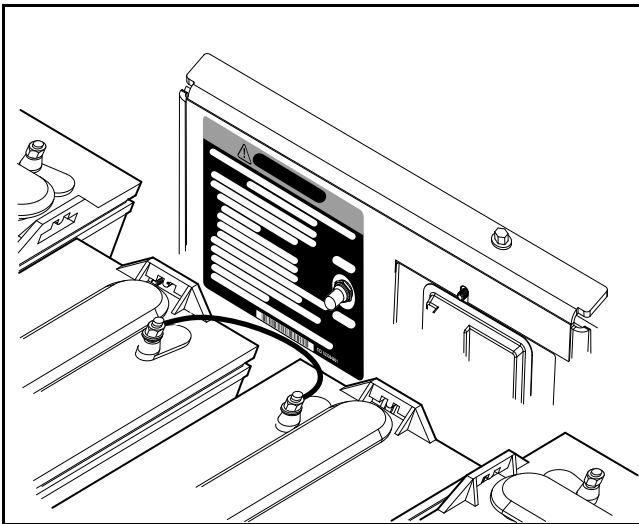

1381

Figure 14 Tow/Run Switch

The Tow/Run switch should be placed in the TOW position under the following conditions:

- **Before Towing the Vehicle:** Place the Tow/Run switch in the TOW position to disable all motor braking functions, thus preventing possible damage that could occur to the vehicle or electrical components if the vehicle is towed while the walk away braking motor braking function is operating.

- **Before Disconnecting or Connecting Battery Cables:** Place the Tow/Run switch in the TOW position to turn off power to the vehicle electrical system, thus preventing severe arcing and possible battery explosion as the battery cables are disconnected.
- **For Long Term Storage:** Place the Tow/Run switch in the TOW position to turn off power to the vehicle electrical system, thus preventing vehicle electrical components from discharging the batteries.

CONTROLS AND INDICATORS – GASOLINE VEHICLES

See General Warnings on page 11.

⚠ WARNING

- If renting or loaning the vehicle, make sure the driver is familiar with all controls and operating procedures before allowing the vehicle to be driven.
- Do not shift the Forward/Reverse handle while the vehicle is moving. To avoid injury to an unsuspecting passenger or damage to the vehicle, always bring the vehicle to a full stop before shifting the Forward/Reverse handle.
- Release the accelerator pedal and then press the brake pedal firmly until the vehicle stops. To avoid unintentionally starting or rolling the vehicle, set the park brake, place the Forward/Reverse handle in the NEUTRAL position, turn the key switch to the OFF position, and remove the key.
- Do not tamper with the governor. Doing so will void the warranty, as well as damage the engine and other components, and could result in property damage, personal injury, or death due to unsafe speed.

KEY SWITCH

The key switch is mounted on the dash to the right of the steering column (**Figure 15**). It has two positions, OFF and ON, which are clearly labeled. **See following NOTE.**

NOTE: When the key is turned to the OFF position, the main vehicle systems are disabled. The key switch may be used as an emergency stop.

The key can be removed only when the key switch is in the OFF position.

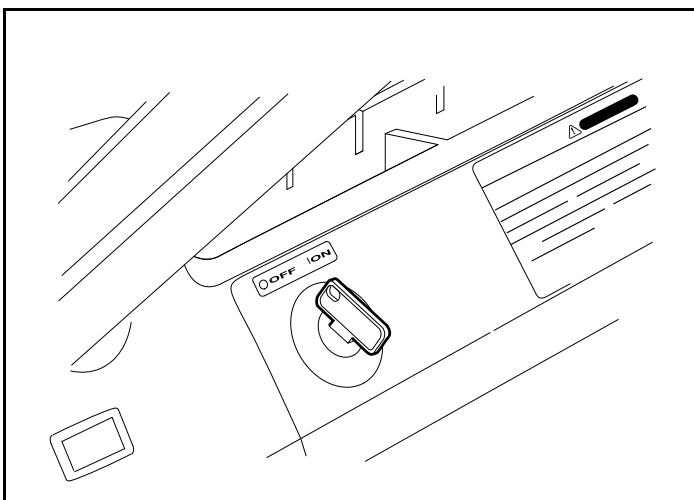

Figure 15 Key Switch

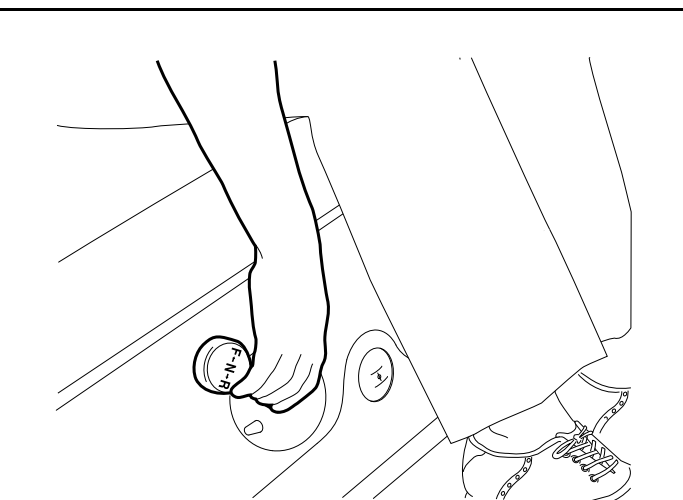

Figure 16 Forward/Reverse Handle

FORWARD/REVERSE CONTROL

The Forward/Reverse handle is located on the seat support panel, below and to the right of the driver's right knee (**Figure 16**). The handle has three distinct positions: F (FORWARD), N (NEUTRAL), and R (REVERSE). Rotate the handle towards the driver (FORWARD) to operate the vehicle in the forward direction, or towards the passenger (REVERSE) to operate the vehicle in reverse. When the handle is in the straight up position, (NEUTRAL), the vehicle will not operate. The engine will stop if it is shifted to this position during operation. Club Car vehicles operate at reduced speed in reverse. The reverse buzzer will sound as a warning when the Forward/Reverse handle is in the REVERSE position.

ACCELERATOR PEDAL

The accelerator pedal is the pedal on the right, with the word GO molded into it (**Figure 17**). The operation of the accelerator pedal differs from that of an automobile. When the key switch is in the ON position, and the Forward/Reverse handle is in either the FORWARD or REVERSE position, pressing the accelerator pedal will automatically release the park brake and start the vehicle moving in the direction selected (forward or reverse). As the accelerator pedal is pressed, speed will increase until full speed is reached. When the accelerator is released, power will be cut off and the motor will stop running.

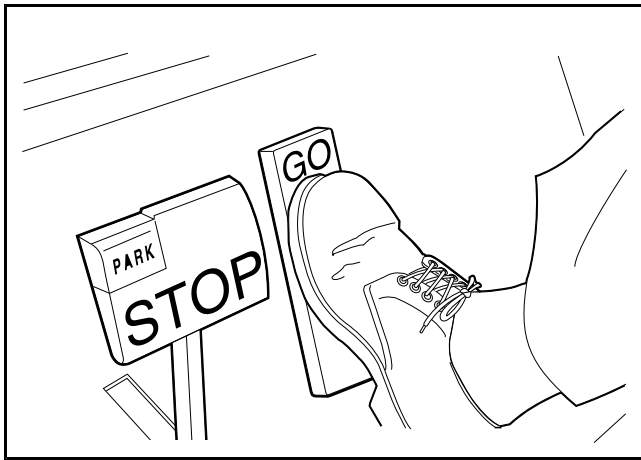

77

Figure 17 Accelerator Pedal

BRAKE PEDAL

The brake pedal is the large pedal on the left with the word STOP molded into it. To slow or stop the vehicle, press the brake pedal with your foot (**Figure 18**).

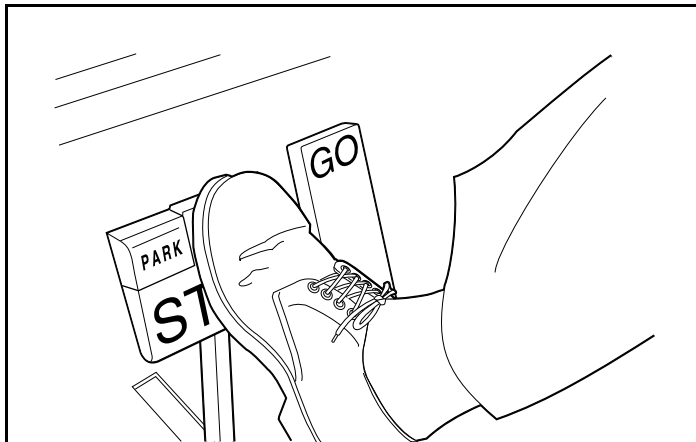

78

Figure 18 Brake Pedal

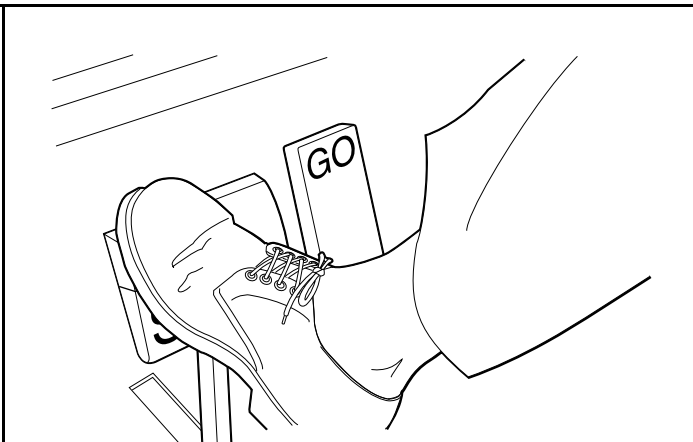

79

Figure 19 Park Brake Pedal

PARK BRAKE PEDAL

The park brake pedal is the small raised portion in the upper left corner of the brake pedal. It has the word PARK molded into it. To set the park brake, press the brake pedal firmly and tilt the park brake portion of the pedal forward with your foot (Figure 19). See following WARNING and NOTE.

▲ WARNING

- The park brake will release automatically when either the accelerator or brake pedal is pressed. The park brake has multiple locking positions and should be firmly pressed and locked to prevent the vehicle from rolling.

NOTE: Vehicles equipped with lights: On early 2009 model gasoline vehicles, after the park brake is engaged, the brake lights may remain illuminated for up to four minutes.

NEUTRAL LOCKOUT

For the convenience of the trained technician, there is a neutral lockout cam located on the back of the Forward/Reverse shifter. If the neutral lockout cam is pulled out approximately 3/8 inch (10 mm) and then rotated one-half turn until it snaps into place, the cam will be in the MAINTENANCE position (Figure 20). This will allow the technician to operate the engine in neutral for certain maintenance procedures. With the cam in this position, the vehicle will not operate if the Forward/Reverse handle is placed in either the FORWARD or REVERSE position.

To put the cam back into the OPERATE position, pull the cam out approximately 3/8 inch (10 mm) and rotate it one-half turn until it snaps into place (Figure 21). See following WARNING and NOTE.

▲ WARNING

- With the cam in the MAINTENANCE position and the engine running, the vehicle may move suddenly if the Forward/Reverse handle is shifted or accidentally bumped. To prevent this, chock the front and rear wheels and firmly set the park brake before servicing or leaving the vehicle.

NOTE: Be sure to return the cam to the OPERATE position after servicing the vehicle, or it will not operate with the Forward/Reverse handle in either the FORWARD or REVERSE position.

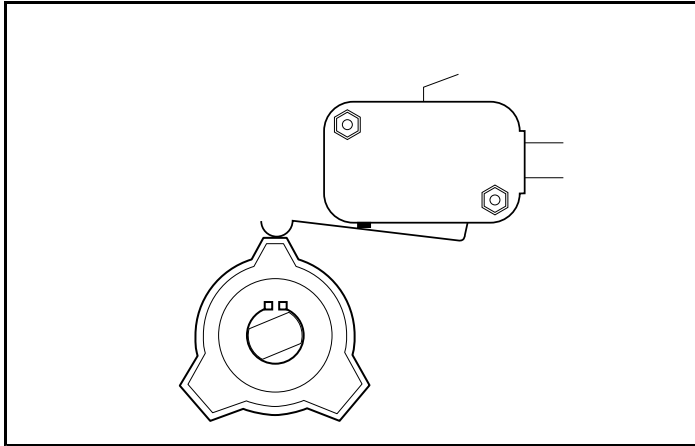

60 **Figure 20 Neutral Lockout – Maintenance Position**

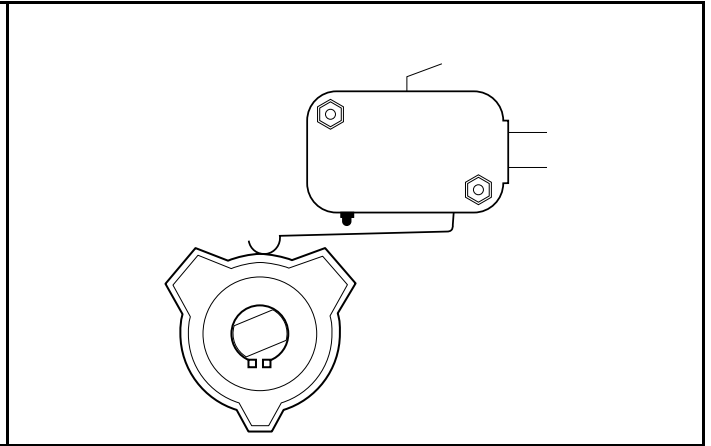

61 **Figure 21 Neutral Lockout – Operate Position**

CHOKE

The choke is located on the seat support panel below and to the right of the driver's right knee (**Figure 22**). If the vehicle is hard to start in cool or cold temperatures, simply push in the choke cover to activate it. Hold it during start up and release the choke cover after the engine starts and runs smoothly.

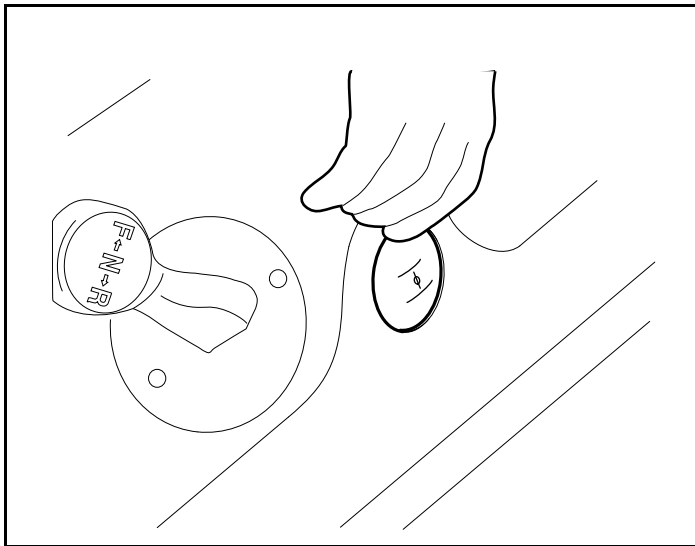

62 **Figure 22 Choke**

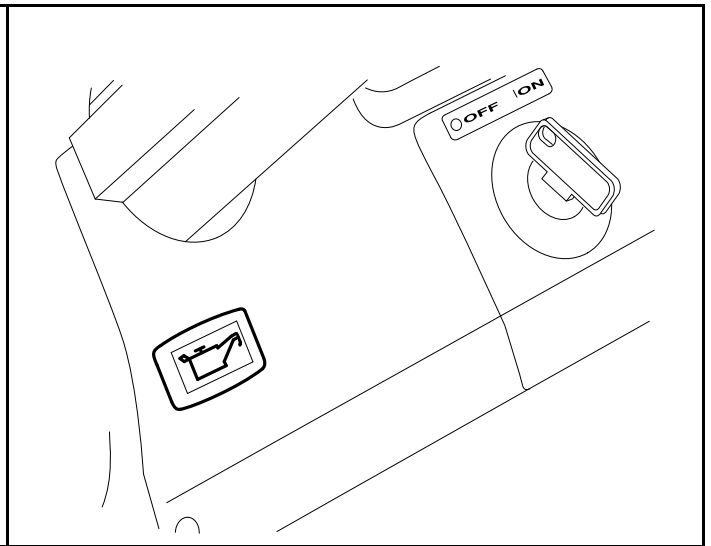

63 **Figure 23 Low Oil Warning Light**

LOW OIL WARNING LIGHT

The gasoline golf car is equipped with a low oil warning light, located on the dash panel just below the steering column (**Figure 23**). If the warning light comes on, oil should be checked and added to the engine as necessary before

continuing to use the vehicle. The vehicle should never be driven with the low oil warning light remaining on. If the warning light goes on and off, you may proceed, but oil should be added at the first opportunity. If the oil level is correct and the warning light stays on, have a trained technician check the vehicle. **See following CAUTION.**

CAUTION

- **Failure to add oil immediately when the low oil warning light stays on may result in permanent engine damage.**

PRE-OPERATION AND DAILY SAFETY CHECKLIST

Each Club Car vehicle has been thoroughly inspected and adjusted at the factory; however, upon receiving your new vehicle(s), you should become familiar with its controls, indicators, and operation. Carefully inspect each vehicle to ensure that it is in proper working condition before accepting delivery.

Use the following checklist as a guide to inspect the vehicle. This checklist should be used daily to ensure that the vehicle is in proper working condition and in conjunction with the Performance Inspection on page 27, and the Periodic Service Schedules on page 35. Any problems should be corrected by a Club Car distributor/dealer or a trained technician.

Any vehicle not functioning correctly should be removed from use until it is properly repaired. This will prevent further damage to the vehicle and avoid the possibility of injury due to unsafe conditions.

All Vehicles

- **General:** All the parts should be in place and properly installed. Be sure that all nuts, bolts, and screws are tight.
- **Safety and information decals:** Check to ensure that all safety and information decals are in place. **See Safety Decal and Feature Identification on page 4.**
- **Tires:** Check for proper tire pressure. Visually inspect tires for wear, damage, and proper inflation on a daily basis. **See Vehicle Specifications on page 59.**
- **Performance Inspection:** Inspect as instructed. **See Performance Inspection on page 27.**

Electric Vehicles

- **Batteries:** Check electrolyte to ensure that it is at its proper level (**Figure 28, Page 45**). Check battery posts. Wires should be tight and free of corrosion. Charge batteries fully before first use of vehicle.
- **Charger cord, plug, and receptacle:** Visually inspect for cracks, loose connections, and frayed wiring. **See Plug and Receptacle on page 48.**

Gasoline Vehicles

- **Battery:** Check electrolyte to ensure it is at the proper level (**Figure 36, Page 52**). Check battery posts. Wires should be tight and free of corrosion and battery should be fully charged.
- **Engine:** Check for proper engine oil level. **See Engine Oil – Gasoline Vehicles on page 52.**
- **Fuel:** Check fuel level. **See Fueling Instructions – Gasoline Vehicles on page 55.** Check fuel tank, lines, cap, pump, fuel filters, and carburetor for fuel leakage.
- **Exhaust system:** Check for leaks.

⚠ WARNING

- **Be sure the plastic has been removed from the seat bottom before operating the vehicle. Failure to do so may result in a fire, property damage, personal injury, or death.**

PERFORMANCE INSPECTION

After you have familiarized yourself with the vehicle controls and have read and understood the driving instructions, take the vehicle for a test drive.

Use the following checklist in conjunction with the Daily Pre-Operation and Safety Checklist as a guide to inspect the vehicle and check daily for proper operation. Any problems should be corrected by a Club Car distributor/dealer or a trained technician.

All Vehicles

- **Forward/Reverse switch:** Check for proper operation. **See Controls and Indicators – Electric Vehicles on page 17 or Controls and Indicators – Gasoline Vehicles on page 22.**
- **Brakes:** Be sure the brakes function properly. When brake pedal is pressed using moderate pressure, the vehicle should come to a smooth, straight stop. If the vehicle swerves or fails to stop, stops abruptly, or makes a grinding or squeaking noise, have the brake system checked and adjusted as required. Continued, moderate brake pedal pressure should be able to lock the wheels, but using lesser pressure should also permit a slow, gradual deceleration.
- **Park brake:** When latched, the park brake should lock the wheels and hold the vehicle stationary (on an incline of 20% or less). It should release when either the accelerator or brake pedal is pressed.
- **Reverse buzzer:** The reverse buzzer will sound as a warning when the Forward/Reverse handle or switch is in the REVERSE position.
- **Steering:** The vehicle should be easy to steer and should not have any play in the steering wheel.
- **General:** Listen for any unusual noises such as squeaks or rattles. Check the vehicle's ride and performance. Have a Club Car distributor/dealer or a trained technician investigate anything unusual.

Electric Vehicles

- **Accelerator:** With the key switch in the ON position and the Forward/Reverse switch in the FORWARD position, as the accelerator pedal is pressed, the motor should start and the vehicle should accelerate smoothly to full speed. When the pedal is released it should return to the original position. All Club Car vehicles operate at reduced speed in reverse.
- **Walk Away Braking:** With the vehicle parked on level ground and the park brake disengaged, place the Tow/Run switch in the RUN position and attempt to push the vehicle. Motor braking should engage and cause resistance to rolling (moving at no more than 1 to 3 mph) (1.5 to 4.8 km/h) with the Forward/Reverse switch in any position. When walk away motor braking is engaged, the reverse buzzer should emit a distinct pattern of beeps. **See following WARNING.**

WARNING

- **Walk Away Braking will not limit vehicle speed to 1 mph (1.6 km/h) on very steep grades. Do not operate vehicle on slopes exceeding 20% grades.**

Excel System Vehicles

- **Motor Braking:** Accelerate down an incline with the accelerator pedal fully pressed. When the vehicle reaches maximum programmed speed, motor braking should engage and limit the vehicle to its maximum programmed speed. On very steep grades, the vehicle may slightly exceed its maximum programmed speed, requiring the use of the brake pedal. Also, travel downhill with the accelerator pedal partially pressed. Motor braking should limit speed to less than top speed and maintain speeds proportional to the accelerator pedal position. On a level surface, accelerate the vehicle to full speed and then release the accelerator pedal. Motor braking should smoothly slow the vehicle to a complete stop or else allow the vehicle to coast freely, depending on the selected controller setting.

IQ System Vehicles

- **Pedal Up Motor Braking:** Accelerate the vehicle to full speed and then release the accelerator pedal. Motor braking should quickly and smoothly slow the vehicle to approximately 11 mph (17.7 km/h). Motor braking will disengage when vehicle slows to 11 mph (17.7 km/h).
- **Pedal Down Motor Braking:** Accelerate down an incline with the accelerator pedal pressed. When the vehicle reaches maximum programmed speed, motor braking should engage and limit the vehicle to its maximum

programmed speed. On very steep grades, the vehicle may slightly exceed its maximum programmed speed, requiring the use of the brake pedal.

Gasoline Vehicles

- **Accelerator:** With the key switch in the ON position and the Forward/Reverse switch in the FORWARD position, as the accelerator pedal is pressed, the engine should start and the vehicle should accelerate smoothly to full speed. When the pedal is released it should return to the original position. All Club Car vehicles operate at reduced speed in reverse.
- **Governor:** Check maximum speed of the vehicle. The vehicle should operate at 12-15 mph (19-24 km/h) on a level surface.

DRIVING INSTRUCTIONS

WARNING

- Only licensed drivers should be allowed to drive the vehicle.
- If renting or loaning the vehicle, make sure the driver is familiar with all controls and operating procedures before allowing the vehicle to be driven.
- No more than two persons per bench seat should be on the vehicle at one time. Do not allow passenger to ride in the bag well.
- The vehicle is not specially equipped for handicapped persons. Be sure all persons can properly operate the vehicle prior to allowing them to drive the vehicle.
- Be sure all passengers are capable of securing themselves in a vehicle before allowing them to ride in one.
- For night use, the vehicle must be equipped with headlights and taillights.
- Stop the vehicle before shifting the Forward/Reverse switch. Failure to do so may result in injury to an unsuspecting passenger and (or) damage to the vehicle.
- To help avoid being struck, do not stand in front of or behind the vehicle.
- Operate the vehicle from the driver seat only.
- To help prevent falls from the vehicle, remain seated in a moving vehicle and hold on to hand holds or handrails at all times. Driver should keep both hands on the steering wheel when the vehicle is in motion.
- To help prevent the possibility of serious injury, keep your entire body inside the vehicle.
- Do not leave children unattended on vehicle.
- To help prevent overturning the vehicle, drive slowly straight up and down slopes. Avoid driving the vehicle on slopes exceeding 20% incline.
- To help avoid possible injury to an inattentive passenger and (or) damage to the vehicle, avoid sudden starts, sudden stops, and abrupt turns.
- To help avoid the possibility of losing control of or overturning the vehicle, reduce speed for adverse driving conditions such as wet grass or rough terrain.
- Do not use the vehicle on public roads. It is not designed or intended for street use and should not be licensed for use on public roads.
- Obey all local rules concerning golf cars.
- The vehicle should be driven in only specified areas by trained drivers.
- Do not drive while under the influence of alcohol, drugs, or medications.
- To prevent overturning the vehicle, drive slowly in turns.
- Use brakes to reduce speed when coasting downhill.

WARNING CONTINUED ON NEXT PAGE

WARNING

- **This vehicle is not intended to be used where risk of falling objects exists. If your vehicle will be used in such an environment, contact your local dealer.**
- **Do not drive the vehicle under tree limbs, bridges, tunnels, or other objects that are less than 80 inches (203 cm) from the ground.**

No one should drive the vehicle without first being instructed in the proper operation and use of the vehicle's controls. An experienced operator should accompany each first-time driver on a test drive before allowing him/her to operate the vehicle alone.

To ensure safe operation of the vehicle, follow exactly and in order, all of the following procedures. Read and understand all instructions prior to driving the vehicle.

STARTING THE VEHICLE

1. Study and understand controls.
2. Make sure everyone is seated and holding onto seat handles or handrails.
3. Read safety and information decals located on the vehicle.
4. Make sure wheels are turned in desired direction.
5. Turn the key to the ON position and make sure nothing is in your path.
6. Select direction by placing Forward/Reverse handle or switch in desired position (F = forward or R = reverse). A buzzer will sound as a warning when the Forward/Reverse handle or switch is in the REVERSE position.
7. Slowly press accelerator pedal. The park brake will release automatically and the vehicle will start to move. As the accelerator pedal is pressed, speed will increase until full speed is reached. **See following WARNING.**

WARNING

- **Operator must control vehicle speed when going downhill.**

Electric vehicles:

- **Pedal down or pedal up motor braking may be used to help control speed when going downhill; however, steep terrain or other conditions will require that pedal braking be used in conjunction with motor braking.**

Gasoline Vehicles:

- **Do not shift the vehicle out of forward while going downhill. If you do, you will not be able to shift into reverse or back into forward until stopped.**
- **Press the brake pedal as necessary and partially press the accelerator when descending a hill. With the accelerator pedal partially pressed, the governor will cause the engine to assist the brakes in controlling downhill speed.**

NOTE: *If the Forward/Reverse handle is shifted into the NEUTRAL position, power will be cut off and the engine will stop running.*

STOPPING THE VEHICLE

WARNING

- **Driving through water may affect the brakes. After driving through water, check effectiveness of the brakes by gently pressing the brake pedal. If the vehicle does not slow down at the normal rate, continue to press the brake pedal until the brakes dry out and normal performance returns.**

⚠ CAUTION

- **When stopped on a hill, use the brake pedal to hold your position. Do not use the accelerator pedal to hold position.**

To stop the vehicle, release the accelerator pedal and press the brake pedal with your right foot until the vehicle comes to a complete stop.

PARKING AND LEAVING THE VEHICLE

1. After stopping the vehicle, firmly press the park brake pedal until it locks and prevents the vehicle from rolling. **See following NOTE.**

NOTE: Vehicles equipped with lights: On early 2009 model gasoline vehicles, after the park brake is engaged, the brake lights may remain illuminated for up to four minutes.

2. Turn the key switch to the OFF position and place the Forward/Reverse handle or switch in the NEUTRAL position. Remove the key when the vehicle is not in use. For gasoline vehicles, also turn off the fuel shut-off valve (**Figure 24**).
3. **Electric vehicles only:** When the Tow/Run switch is in the RUN position, (with the Forward/Reverse switch or key switch in any position), the walk away braking function will prevent the vehicle from rolling at more than 1 to 3 mph (1.5 to 4.8 km/h) unless the accelerator is pressed. This prevents the possibility of a parked vehicle (with the park brake disengaged) rolling away too fast to be overtaken on foot.

TOWING

⚠ WARNING

- **Do not tow the vehicle on public streets or highways.**
- **Use only approved Club Car tow bars.**
- **Turn the key switch to OFF and place the Forward/Reverse handle or switch in the NEUTRAL position before towing the vehicle.**
- **Electric vehicles only: Place the Tow/Run switch in the TOW position; otherwise, the vehicle will not roll while being towed.**
- **Extreme caution should be used when towing any vehicle.**
- **Do not exceed 5 mph (8 km/h) towing speed.**
- **Do not allow people in the vehicles being towed.**
- **Avoid sudden starts, sudden stops, and tight turns when towing.**
- **Avoid stopping on a hill when towing. If you must stop on a hill, avoid sudden starts or rolling backwards and stopping suddenly. Failure to heed this warning could cause the vehicle to overturn, possibly resulting in severe personal injury.**
- **Do not tow more than one Club Car vehicle with another Club Car vehicle. If more than one vehicle must be towed, an adequately powered vehicle (tractor or full sized truck) properly fitted, with a tow hitch height of 11 inches (28 cm) should be used. Only heavy-duty tow bars should be used for multi-vehicle towing. Never tow more than five vehicles at one time.**
- **Gasoline vehicles only: Turn the fuel shut-off valve to closed (OFF) position (Figure 24).**

A light duty tow bar is available for break-down towing and single vehicle towing. A heavy duty tow bar and an onboard tow bar are available for multi-vehicle towing. Observe all of the previous WARNING statements when towing.

TRANSPORTING ON A TRAILER

WARNING

- For use on public roads, the trailer must meet all federal, state, and local requirements such as taillights, brake lights, etc.
- Do not tow a Club Car vehicle behind a passenger vehicle or truck on a public road unless it is on an approved trailer.
- The vehicle to be towed should be tied securely to the trailer, with the Forward/Reverse handle or switch in the NEUTRAL position, the key switch the OFF position, and the park brake firmly pressed and locked to prevent movement.
- Do not allow people in the trailer or vehicle being towed.
- Avoid sudden starts, sudden stops, and tight turns when towing.
- Avoid stopping on a hill when towing. If you must stop on a hill, avoid sudden starts or rolling backwards and stopping suddenly. Failure to heed this warning could cause the vehicle to overturn, possibly resulting in severe personal injury.
- When towing on a trailer, normal road speed of the tow vehicle should be reduced.
- Because of the added length of the trailer, use caution when making turns.
- Remove the vehicle windshield and secure the seat bottom before transporting on a trailer.
- Gasoline vehicles only: Turn the fuel shut-off valve to the closed (OFF) position (Figure 24).

If the vehicle must be transported over long distances or on public highways, it should be transported on an approved trailer that has the approved load rating of 1200 lb. (544 kg) per vehicle being transported.

NOTE: A two-car trailer should be rated at $2 \times 1200 = 2400$ lb. ($2 \times 544 = 1088$ kg).

STORAGE – ELECTRIC VEHICLE

See General Warnings on page 11.

WARNING

- Turn the key switch to the OFF position, remove the key, and leave the Forward/Reverse switch in the NEUTRAL position during storage. Place Tow/Run switch in the TOW position. This is to prevent unintentionally starting the vehicle or a fire hazard.
- Do not attempt to charge frozen batteries or batteries with bulged cases. Discard the battery. Frozen batteries can explode.

CAUTION

- Batteries in a low state of charge will freeze at low temperatures.
- To avoid exposing electrical components to moisture and subsequent damages, do not use any type of pressure washing or steam cleaning equipment to wash the vehicle.

PREPARING THE ELECTRIC VEHICLE FOR EXTENDED STORAGE

1. Fully charge batteries. See **Charging Batteries** on page 47.
2. Batteries should be clean and free of corrosion. Wash tops and terminals of batteries with a solution of baking soda and water (1 cup (237 mL) baking soda per 1 gallon (3.8 L) of water). Rinse solution off batteries. Do not

allow this solution to enter the batteries. Be sure terminals are tight. Let the terminals dry and then coat them with Battery Terminal Protector Spray (CC P/N 1014305).

3. Store vehicle in a cool, dry place. This will minimize battery self-discharge.
4. Adjust tires to recommended tire pressure. **See Vehicle Specifications on page 59.**
5. Perform all semiannual periodic lubrication. **See Periodic Lubrication Schedules on page 40.**
6. Thoroughly clean front body, rear body, seats, battery compartment, and underside of vehicle.
7. Do not engage the park brake. Chock the wheels to prevent the vehicle from rolling.
8. Keep batteries fully charged during storage.
 - 8.1. Leave battery chargers plugged in during storage. The onboard computer (OBC) will automatically activate the charger when necessary.
 - 8.2. If the battery charger is left plugged in during extended storage, check the electrolyte level and charger function monthly to ensure that proper operation is maintained. To check charger function, disconnect the DC cord (stationary charger) from the vehicle or the AC cord (onboard charger) from the power source, wait five seconds, then reconnect it. The charger is functioning properly if the ammeter indicates current.

NOTE: The OBC keeps track of the time spent in storage mode. When the OBC detects that the storage charge cycles may have depleted the available electrolyte, it will stop the charger from further operation.

Disconnecting then reconnecting the DC cord (stationary charger) or AC cord (onboard charger) indicates the electrolyte levels have been maintained and allows the OBC to resume operation.

While in storage, the Tow/Run switch should be in Tow. When in Tow mode, the amber battery warning light will not illuminate. Do not attempt to use the battery light as an indication of battery state while in storage.

- 8.3. If AC power is off for 7 days or longer, the OBC will not function or charge the vehicle again until it has been restarted. To restart the computer, make sure AC power has been restored, disconnect the DC cord (stationary charger) from the vehicle or the AC cord (onboard charger) from the power source, wait five seconds, then reconnect it.

CAUTION

- **Be sure to check the batteries and charger monthly to maintain correct battery water level and to ensure the charger is operating correctly during storage.**
- 8.4. If the charger cannot remain plugged in, AC power will not be available during extended storage, or electrolyte levels will not be maintained, then disconnect the batteries for storage (**Figure 2, Page 13**) or (**Figure 3, Page 14**).

RETURNING THE STORED ELECTRIC VEHICLE TO SERVICE

1. If necessary, connect batteries. **See Connecting the Batteries – Electric Vehicles on page 14.**
2. Fully charge batteries.

⚠ WARNING

- **Do not attempt to charge frozen batteries or batteries with bulged cases. Discard the battery. Frozen batteries can explode.**
3. Adjust tires to recommended tire pressure. **See Vehicle Specifications on page 59.**
 4. Perform the Pre-Operation and Daily Safety Checklist on page 26.

STORAGE – GASOLINE VEHICLE

See General Warnings on page 11.

⚠ DANGER

- Do not attempt to drain fuel when the engine is hot or while it is running.
- Be sure to clean up any spilled gasoline before operating the vehicle.
- Store fuel in an approved fuel container only. Store in a well-ventilated area away from sparks, open flames, heaters, or heat sources.
- Keep fuel out of the reach of children.
- Do not siphon fuel from the vehicle.

⚠ WARNING

- Turn the key switch to the OFF position, remove the key, and leave the Forward/Reverse handle in the NEUTRAL position during storage. This is to prevent unintentionally starting the vehicle or a fire hazard.
- Turn the fuel shut-off valve to closed (OFF) position (Figure 24).

⚠ CAUTION

- Batteries in a low state of charge will freeze at low temperatures.

PREPARING THE GASOLINE VEHICLE FOR EXTENDED STORAGE

1. Store vehicle in a cool, dry place. This will minimize battery self-discharge. If the battery appears to be weak, have it charged by a trained technician. Use an automotive-type 12-volt battery charger rated at 10 amps or less.
2. Drain carburetor and seal the fuel tank.
 - 2.1. Place the Forward/Reverse handle in the NEUTRAL position and the neutral lockout cam in the MAINTENANCE position. Turn the fuel shut-off valve to the closed (OFF) position (**Figure 24**) and run the engine until fuel remaining in the carburetor and fuel lines is depleted and the engine stalls. Return the neutral lockout cam to the OPERATE position.
 - 2.2. Loosen, but do not remove, the carburetor drain screw and drain fuel remaining in bowl into a small, clean container, then pour the fuel from the container into vehicle fuel tank. Tighten the carburetor drain screw.
 - 2.3. Disconnect fuel vent line from fuel tank vent nipple.
 - 2.4. Plug the fuel tank vent nipple so that it is air tight. We recommend using a slip-on vinyl cap.
3. Disconnect battery and spark plug wire(s). **See Disconnecting the Battery – Gasoline Vehicles on page 13.**
4. Battery should be clean and free of corrosion. Wash top and terminals of battery with a solution of baking soda and water (1 cup (237 mL) baking soda per 1 gallon (3.8 L) of water). Rinse solution off battery. Do not allow this solution to enter the battery. Let the terminals dry and then coat them with Battery Terminal Protector Spray (CC P/N 1014305).
5. To protect the engine, remove spark plug and pour 1/2 ounce (14.2 mL) of SAE 10 weight oil into the engine through the spark plug hole. Rotate engine crankshaft by hand several times and then install the spark plug.
6. Adjust tires to recommended tire pressure. **See Vehicle Specifications on page 59.**
7. Perform semiannual periodic lubrication. **See Periodic Lubrication Schedules on page 40.**
8. Thoroughly clean front body, rear body, seats, engine compartment, and underside of vehicle.
9. Do not engage the park brake. Chock the wheels to prevent the vehicle from rolling.

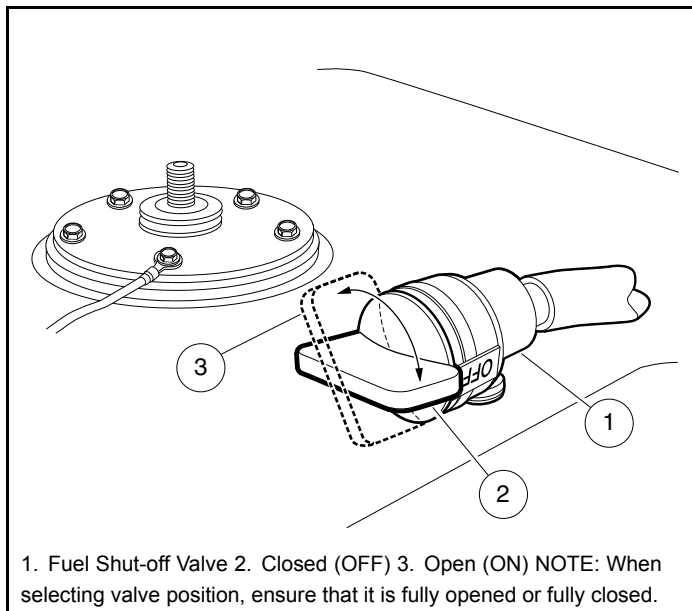

614 **Figure 24 Fuel Shut-off Valve**

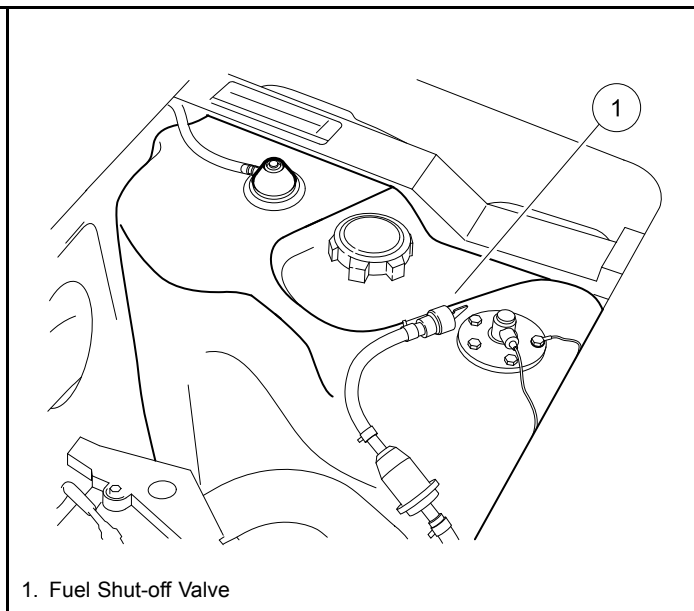

63A

Figure 25 Fuel Tank

RETURNING THE STORED GASOLINE VEHICLE TO SERVICE

1. Restore the fuel systems to operation (**Figure 25**).
 - 1.1. Remove the plug from the fuel tank vent.
 - 1.2. Connect the vent tube to the fuel tank vent.
2. Connect battery and spark plug wire(s). **See Connecting the Battery – Gasoline Vehicles on page 13.**
3. Completely open the fuel shut-off valve (1) (**Figure 24**). Make sure the valve is fully open. A partially closed fuel shut-off valve combined with the use of the choke can result in a fouled spark plug and engine failure.
4. Place the Forward/Reverse handle in the NEUTRAL position and the neutral lockout cam in the MAINTENANCE position. Crank the engine until fuel is pumped into the carburetor and fuel lines and the engine starts. Turn the engine off and return the neutral lockout cam to the OPERATE position. **See following NOTE.**

NOTE: Due to the oil added to the engine in preparation for storage, engine may smoke excessively for a short time when it is run for the first time after storage.

5. Adjust tires to recommended tire pressure. **See Vehicle Specifications on page 59.**
6. Perform the Pre-Operation and Daily Safety Checklist on page 26.

MAINTENANCE

See General Warnings on page 11.

To ensure trouble-free vehicle performance, it is very important to follow an established preventive maintenance program. Regular and consistent vehicle maintenance can prevent vehicle downtime and expensive repairs that can result from neglect. Use the Pre-Operation and Daily Safety Checklist beginning on page 27, the Performance

Inspection, and the following Periodic Service Schedules and Periodic Lubrication Schedules to keep the vehicle in proper working condition.

Any vehicle not functioning correctly should be removed from use until it is properly repaired. This will prevent further damage to the vehicle and avoid the possibility of injury due to unsafe conditions.

Contact your local Club Car distributor/dealer to perform all repairs and semiannual and annual periodic service.

WARNING

- If any problems are found during scheduled inspection or service, do not operate the vehicle until repairs are made. Failure to make necessary repairs could result in fire, property damage, severe personal injury, or death.
- Only trained technicians should service or repair the vehicle or battery charger. Anyone doing even simple repairs or service should have knowledge and experience in electrical and mechanical repair. The appropriate instructions must be used when performing maintenance, service, or accessory installation.

Electric vehicles:

- Hot! Do not attempt to service hot motor. Attempting to do so could cause severe burns.
- To avoid unintentionally starting the vehicle, disconnect the batteries and discharge the controller. See Disconnecting the Batteries – Electric Vehicles on page 14.

Gasoline vehicles:

- Moving parts: Do not attempt to service gasoline vehicle while the engine is running.
- Hot! Do not attempt to service hot engine or exhaust system. Failure to heed this warning could result in severe burns.
- Turn the fuel shut-off valve to the closed (OFF) position (Figure 24).
- To avoid unintentionally starting the vehicle, disconnect battery and spark plug wire(s). See Disconnecting the Battery – Gasoline Vehicles on page 13.
- Frame ground – Do not allow tools or other metal objects to contact frame when disconnecting batteries or other electrical wiring. Never allow a positive wire to touch the vehicle frame, engine, or other metal component.

PERIODIC SERVICE SCHEDULES

WARNING

- Service, repairs, and adjustments must be made per instructions in the maintenance and service manual.

NOTE: *If the vehicle is constantly subjected to heavy use or severe operating conditions, the preventive maintenance procedure should be performed more often than recommended in the periodic service and lubrication schedules.*

Both the Periodic Service Schedule and Periodic Lubrication Schedule must be followed to keep vehicle in optimum operating condition.

PERIODIC SERVICE SCHEDULE – ELECTRIC VEHICLES		
REGULAR INTERVAL	SERVICE	
Daily service by owner	Pre-Operation and Daily Safety Checklist	See Pre-Operation and Daily Safety Checklist on page 26.
	Performance Inspection	See Performance Inspection on page 27.
	Batteries	Charge batteries (after each daily use only).
Weekly service by owner	Batteries (For vehicles NOT equipped with the Single-Point Watering System)	Check electrolyte level. Add water if necessary. See Battery Care – Vehicles Without the Single-Point Watering System on page 44.
Monthly service by owner or trained technician	Batteries (For vehicles equipped with the Single-Point Watering System). Water monthly or according to the established watering interval.	Water the batteries. Observe that water flow occurs and no water overflows from any cell. See Battery Care – Vehicles Equipped with the Single-Point Watering System on page 43.
	Batteries	Wash battery tops and clean terminals with baking soda/water solution. Apply Battery Terminal Protector Spray (CC P/N 1014305) to battery terminals.
	Tires	Check air pressure and adjust if necessary. See Vehicle Specifications on page 59.
	General Vehicles	Thoroughly wash vehicle including the underside.
Initial (one-time) inspection by owner or trained technician after six weeks of use	Batteries (For vehicles newly equipped with the Single Point Watering System)	For vehicles newly equipped with the SPWS, manually check battery electrolyte levels of all cells to verify correct valve operation. See page 42.
Semiannual service by trained technician only (every 50 hours of operation or 100 rounds of golf)	Brake system	Check brake shoes; replace if necessary.
		Lubricate brake system per Lubrication Schedule.
		Check brake cables for damage; replace if necessary.
		Check brake cable equalizer adjustment; adjust if necessary.
	Electrical wiring and connections	Check for tightness and damage; replace if necessary.
Front wheel alignment and camber	Check and adjust as required. See Section 7 – Steering and Front Suspension in the appropriate maintenance and service manual.	
Annual service by owner or trained technician (every 100 hours of operation or 200 rounds of golf)	Batteries (For vehicles equipped with the Single Point Watering System)	Manually check battery electrolyte levels of all cells to verify correct valve operation. See page 42.

PERIODIC SERVICE SCHEDULE – ELECTRIC VEHICLES		
REGULAR INTERVAL	SERVICE	
Annual service by trained technician only (every 100 hours of operation or 200 rounds of golf)	Batteries	If batteries are not performing as expected, see Batteries in the maintenance and service manual.
	Pedal group	Lubricate all rotating joints. See Periodic Lubrication Schedules on page 40.
	General Vehicle	Check for loose hardware; tighten if necessary. Refer to the appropriate maintenance and service manual.

PERIODIC SERVICE SCHEDULE – GASOLINE VEHICLES		
REGULAR INTERVAL	SERVICE	
Daily service by owner	Pre-Operation and Daily Safety Checklist	See Pre-Operation and Daily Safety Checklist on page 26.
	Performance Inspection	See Performance Inspection on page 27.
Monthly service by owner or trained technician	Engine	Check engine oil level; change if necessary. Properly dispose of used oil. See Periodic Lubrication Schedules on page 40.
		Check engine cooling air intake; clean if necessary. Visually inspect the unshrouded area around engine exhaust for grass and debris, and clean if necessary.
	Tires	Check air pressure and adjust as necessary. See Vehicle Specifications on page 59.
	General vehicle	Wash engine compartment and underside of vehicle. Do not wash engine when hot.
Semiannual service by trained technician only (every 50 hours of operation or every 100 rounds of golf)	Battery	Clean terminals and wash dirt from casing; Apply Battery Terminal Protector Spray (CC P/N 1014305) to battery terminals; check electrolyte level. See Battery – Gasoline Vehicles on page 51.
	Front wheel alignment and camber	Check and adjust if necessary. See Section 7 – Steering and Front Suspension in the appropriate maintenance and service manual.
	Electrical wiring and connections	Check for tightness and damage; replace if necessary.
	Brake system	Check brake shoes; replace if necessary.
		Lubricate brake system per Lubrication Schedule.
	Check brake cables for damage; replace if necessary.	
	Check brake cable equalizer adjustment; adjust if necessary.	
Annual service by trained technician only (every 100 hours of operation or every 200 rounds of golf)	Engine	Check for leaks around gaskets, fill plugs, etc.
		Inspect, clean and regap spark plug; replace if necessary.
	Engine air intake system	Check air filter element; replace if necessary.
		Check clamps for tightness; check hose for cracks.
Pedal group	Lubricate all rotating joints. See Periodic Lubrication Schedules on page 40.	

PERIODIC SERVICE SCHEDULE – GASOLINE VEHICLES		
REGULAR INTERVAL	SERVICE	
	General vehicle	Check for loose hardware; tighten if necessary. Refer to the appropriate maintenance and service manual.
Two year service by trained technician only (every 200 hours of operation or every 400 rounds of golf)	Fuel filters	Replace. Dispose of used filters properly.

 WARNING

- If any problems are found during scheduled inspection or service, do not operate the vehicle until repairs are made. Failure to make necessary repairs could result in fire, property damage, severe personal injury, or death.

PERIODIC LUBRICATION SCHEDULES

PERIODIC LUBRICATION SCHEDULE – ELECTRIC VEHICLES			
REGULAR INTERVAL	SERVICE	LUBRICATION POINTS	RECOMMENDED LUBRICANT
Semiannually by owner or trained technician (every 50 hours of operation or 100 rounds of golf)	Charger receptacle	1	WD-40
	Brake system, per maintenance and service manual.	2	Dry Moly Lube (CC P/N 1012151), white lithium grease NLGI #2
	Front suspension (two fittings)	3	Chassis Lube - EP NLGI Grade 2
Annually by trained technician only (every 100 hours of operation or 200 rounds of golf)	Check/fill transaxle to plug level	4	22 oz. (0.67 liters) SAE 30 WT. API Class SE, SF, or SG Oil (or higher)
	Pedal group (as required)	5	Dupont™ Performance Dry Multi-Use Lubricant

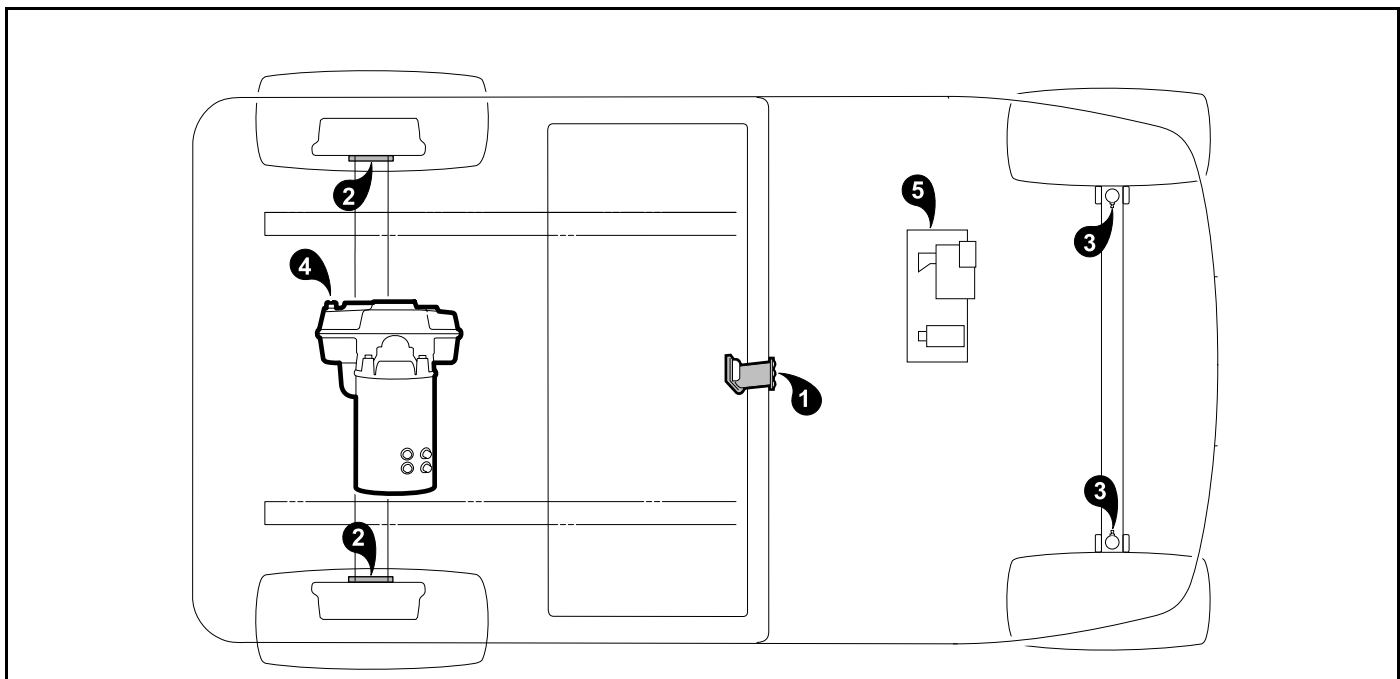

64
Figure 26 Lubrication Points – Electric Vehicles

PERIODIC LUBRICATION SCHEDULE – GASOLINE VEHICLES			
REGULAR INTERVAL	SERVICE	LUBRICATION POINTS	RECOMMENDED LUBRICANT
Semiannually by owner or trained technician (every 50 hours of operation or every 100 rounds of golf)	Shifter cable pivots	1	Dry Moly Lube (CC P/N 1012151)
	Brake system, per maintenance and service manual.	2	Dry Moly Lube (CC P/N 1012151), white lithium grease NLGI #2
	Front suspension (two fittings)	3	Chassis Lube - EP NLGI Grade 2
Annually by trained technician only (every 100 hours of operation or every 200 rounds of golf)	Check/fill unitized transaxle to plug level	4	27 oz. (0.8 liter) 80-90 WT. API Class GL-3 or 80-90 WT. AGMA Class EP Gear Lube
	Pedal group (as required)	5	Dupont™ Performance Dry Multi-Use Lubricant
First change 100 hours – additional change every 200 hours of operation (or every 400 rounds of golf), or annually, whichever comes first	Change engine oil and oil filter (dispose of properly)	6	32 oz. (0.95 liter) without filter; 38 oz. (1.12 liters) with filter

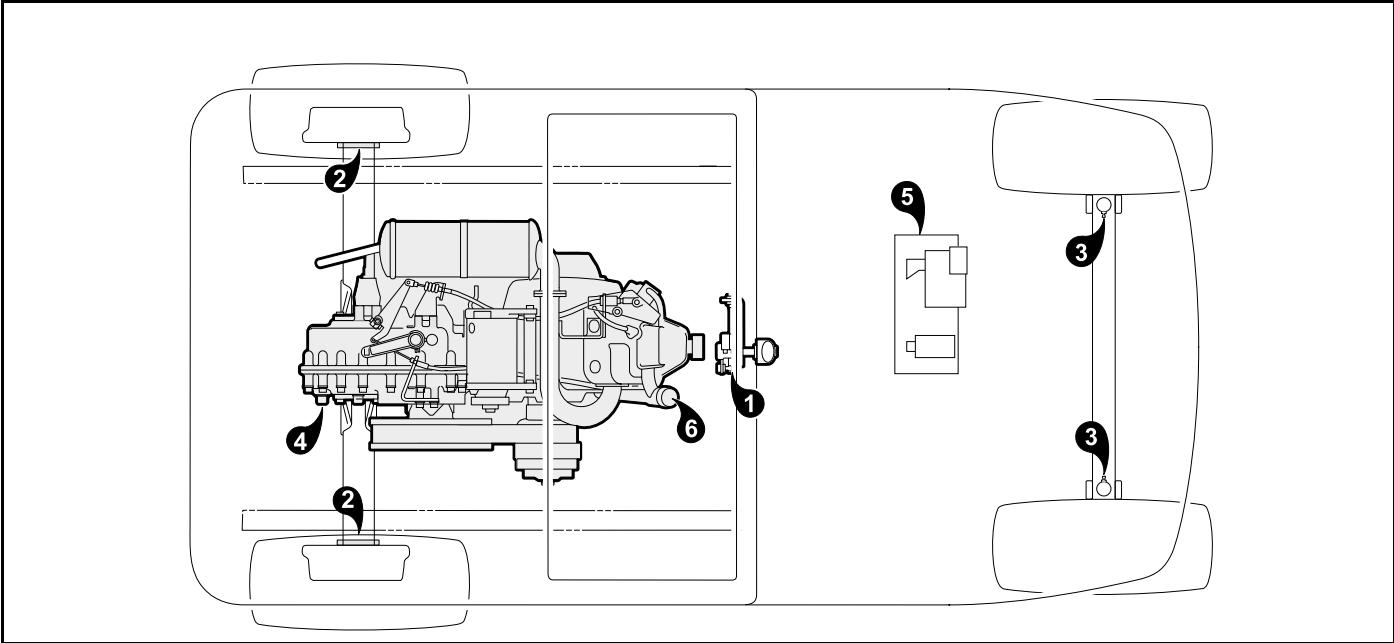

65
Figure 27 Lubrication Points – Gasoline Vehicles

BATTERIES – ELECTRIC VEHICLES

See General Warnings on page 11.

⚠ DANGER

- **Battery – Explosive gases! Do not smoke. Keep sparks and flames away from the vehicle and service area. Ventilate when charging or operating vehicle in an enclosed area. Wear a full face shield and rubber gloves when working on or near batteries.**
- **Charge batteries in a well-ventilated area only. Batteries emit hydrogen while being charged. Hydrogen is an explosive gas and must never exceed a level of 2% of the air.**
- **Battery – Poison! Contains acid! Causes severe burns. Avoid contact with skin, eyes, or clothing. Antidotes:**
 - **External: Flush with water. Call a physician immediately.**
 - **Internal: Drink large quantities of milk or water followed with milk of magnesia or vegetable oil. Call a physician immediately.**
 - **Eyes: Flush with water for 15 minutes. Call a physician immediately.**

⚠ WARNING

- **Wear safety glasses or approved eye protection when servicing the vehicle or battery charger. Wear a full face shield and rubber gloves when working on or near batteries.**
- **Use insulated tools when working near batteries or electrical connections. Use extreme caution to avoid shorting of components or wiring.**

CAUTION

- **On all vehicles, turn off all accessories before charging batteries.**

***NOTE:** Recycle or dispose of discarded batteries in accordance with local, state, and federal regulations.*

Club Car electric vehicles use deep-cycle batteries. Automotive batteries should never be used in electric vehicles.

New batteries will not deliver their full capabilities until they have been discharged and recharged 20 to 50 times. To obtain the maximum service life from new batteries, restrict electric vehicles with new batteries to 36 holes of use between charges in the first two months of operation. Batteries should be fully charged before first use of new vehicle, before first use of a vehicle after storage, and before releasing vehicle for use each day.

WATER QUALITY

To keep batteries in good working condition, the purity of water used is very important. Distilled water is quite pure and is the most common type of water used in batteries. Other acceptable types are deionized water and water from reverse osmosis. Ordinary tap water should not be used because it contains an excessive amount of impurities that will degrade battery performance.

Distilled water is produced by distillation, a process in which water is boiled, the steam is collected and then condensed back into water. This process creates a finished product free of minerals, having left all the impurities in the original water sample. Club Car, along with our battery manufacturers, highly recommends that distilled water be used in electric vehicle batteries.

Deionized water is the purest form of water, but it is also the most expensive. Deionization removes all ionizable particles (organic and inorganic) from water through ion exchange. Positively and negatively charged ions are removed from the water and replaced with H⁺ and OH⁻ ions. When these two ions are combined, they form H₂O, or purified water.

Reverse osmosis is a method of removing solids from water by forcing it through a membrane. The membrane rejects all solids while allowing purified water to pass through. The choice of membrane determines the amount of impurities that the water may contain.

Water from municipal supplies, ponds and wells usually contain detrimental levels of dissolved minerals and chemicals. If using tap water, it is important to use an in-line deionizer to remove impurities that can damage batteries and significantly reduce battery life. If tap water is used without a deionizer, regular water analyses must be conducted to check for impurities because water companies commonly revise their additives on a periodic basis. The following chart lists the maximum allowable minerals, solids, and contaminants in parts per million and their impact on battery performance. Your local water company should be able to perform testing and compare their results to the chart.

If using tap water, Club Car's Service Parts Department offers two different deionizer systems: one for vehicles equipped with the Single Point Water System (SPWS) CC P/N AM1240701 and the other for vehicles without SPWS, CC P/N AM10974.

IMPURITY	ALLOWABLE CONTENT (PARTS PER MILLION)	EFFECTS OF IMPURITY
Suspended matter	Trace	-
Total solids	100.0	-
Organic and volatile matter	50.0	Corrosion of positive plates
Ammonia	8.0	Slight self-discharge of both plates
Antimony	5.0	Self-discharge, reduces life, lower on-charge voltage
Arsenic	0.5	Self-discharge, can form poisonous gas
Calcium	40.0	Increase of positive plate shedding
Chloride	5.0	Loss of capacity in plates, greater loss in positive plates
Copper	5.0	Increased self-discharge, lower on-charge voltage
Iron	3.0	Increased self-discharge, lower on-charge voltage
Magnesium	40.0	Reduced life
Nickel	None allowed	Intense lowering of on-charge voltage
Nitrates	10.0	Increased sulfation of negative plate
Nitrates	5.0	Plate corrosion, loss of capacity, reduced life
Platinum	None allowed	Violent self-discharge, lower on-charge voltage
Selenium	2.0	Positive plate shedding
Zinc	4.0	Slight self-discharge of negative plates

BATTERY CARE – VEHICLES EQUIPPED WITH THE SINGLE-POINT WATERING SYSTEM

WARNING

- **When replacing batteries in the Single Point Watering System, place the battery cap from the new replacement battery onto the used battery being removed from the car. Important safety warnings on the battery cap must remain with the battery after it has been removed from the car.**

To keep batteries in good working condition, follow this maintenance program on a regular basis:

1. Keep the batteries clean and free of corrosion. Wash tops and terminals of batteries with a solution of baking soda and water (1 cup (237 mL) baking soda per gallon (3.8 L) of water). Rinse solution off of the batteries. Do not allow this solution to enter the battery. Be sure terminals are tight. Let the terminals dry and then coat with Battery Terminal Protector Spray (CC P/N 1014305). **See following NOTE.**

NOTE: Dispose of waste water properly.

2. The battery hold-downs should be tight enough so that the batteries do not move while the vehicle is in motion, but not so tight as to crack or buckle the battery case. For 12-volt batteries, tighten hold-down retaining nuts to 72 in-lb (8.1 N·m). For 8-volt batteries, tighten hold-down retaining nuts to 106 in-lb (12 N·m). The terminal connections should be clean and tight, and any worn insulation or frayed wires should be replaced. Tighten battery terminals to proper torque. **See Connecting the Batteries – Electric Vehicles on page 14. See following WARNING.**

⚠ WARNING

- If battery wire terminals are damaged or corroded, replace or clean them as necessary. Failure to do so may cause them to overheat during operation and could result in fire, property damage, or personal injury.
3. After use, charge the batteries. The batteries should never be left discharged any longer than absolutely necessary (do not leave discharged overnight).
 4. Water the batteries monthly or according to the watering interval. **See Establishing the Watering Interval for New Vehicles on page 44. See Watering Batteries with the SPWS on page 49.**

CAUTION

- The watering interval must adequately maintain the electrolyte level above the top of the plates. See Figure 28.
- Water the batteries only **AFTER** charging.

Establishing the Watering Interval for New Vehicles

If you do not already have a battery watering interval for your vehicles, manually check the battery water level weekly to establish the correct watering interval. Thereafter, water batteries according to the established interval. During periods of heavy use, add additional watering as required.

Single-Point Watering System Maintenance

1. For vehicles newly equipped with the Single-Point Watering System, the initial electrolyte level check on all battery cells verifies that all the valves in the SPWS are functioning correctly. **See Periodic Service Schedules on page 35.** If a valve fails to open, the cell will eventually dry out. The initial one-time inspection of all cells will identify any occurrence of a valve that fails to open. If a valve fails to close, it will become evident due to the cell overflowing during routine watering. Either failure scenario is rare, but should be monitored in the initial inspection and during routine watering sessions. Replace malfunctioning valves to ensure maximum battery life. **See following CAUTION.**

CAUTION

- After checking the electrolyte, fully tighten the battery caps to prevent electrolyte leakage.
2. After the initial six-week inspection, manually check the electrolyte level at least once per year, particularly after long-term storage or any other period of vehicle inactivity. **See preceding CAUTION.**

BATTERY CARE – VEHICLES WITHOUT THE SINGLE-POINT WATERING SYSTEM

To keep batteries in good working condition, follow this maintenance program on a regular basis:

1. Keep the batteries clean and free of corrosion. Wash tops and terminals of batteries with a solution of baking soda and water (1 cup (237 mL) baking soda per gallon (3.8 L) of water). Rinse solution off of the batteries. Do

not allow this solution to enter the battery. Be sure terminals are tight. Let the terminals dry and then coat with Battery Terminal Protector Spray (CC P/N 1014305). **See following NOTE.**

NOTE: *Dispose of waste water properly.*

2. Check the electrolyte level weekly (**Figure 28**). Add water only **after** charging unless the electrolyte level is below the top of the plates. In this case, add just enough water to cover the plates, charge, and then check the level again. Never charge batteries if plates are exposed above electrolyte level. For best battery life, add only distilled water. **See following CAUTION and NOTE.**

⚠ CAUTION

- **Do not overfill the batteries.**

NOTE: *A battery watering gun or bottle is available at many auto parts dealers.*

3. The battery hold-downs should be tight enough so that the batteries do not move while the vehicle is in motion, but not so tight as to crack or buckle the battery case. For 12-volt batteries, tighten hold-down retaining nuts to 72 in-lb (8.1 N·m). For 8-volt batteries, tighten hold-down retaining nuts to 106 in-lb (12 N·m). The terminal connections should be clean and tight, and any worn insulation or frayed wires should be replaced. Tighten battery terminals to proper torque. **See Connecting the Batteries – Electric Vehicles on page 14. See following WARNING.**

⚠ WARNING

- **If battery wire terminals are damaged or corroded, replace or clean them as necessary. Failure to do so may cause them to overheat during operation and could result in fire, property damage, or personal injury.**
4. After use, charge the batteries. The batteries should never be left discharged any longer than absolutely necessary (do not leave discharged overnight).

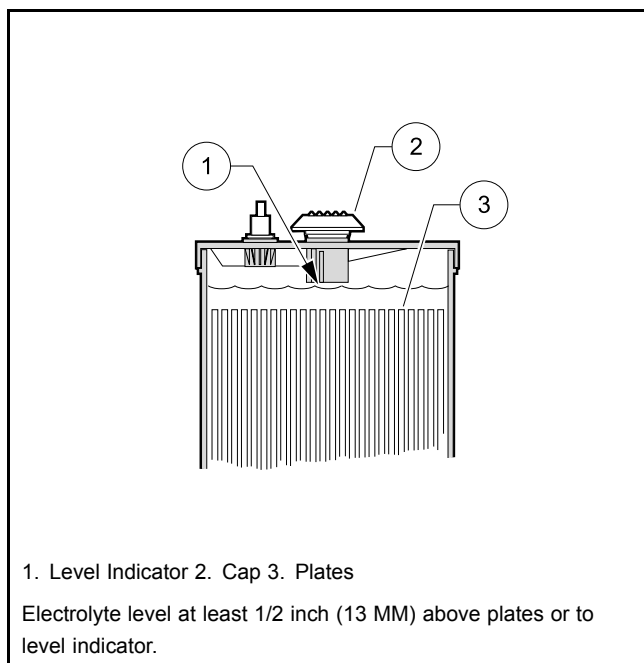

17

Figure 28 Battery Electrolyte Level

BATTERY CHARGER – ELECTRIC VEHICLES

⚠ DANGER

- The charging area must be ventilated. Hydrogen level in the air must never exceed 2%. The total volume of air in the charging area must be changed five times per hour. Exhaust fans should be located at the highest point of the roof. Contact a local HVAC engineer.
- Do not charge the vehicle batteries with the vehicle covered or enclosed. Any enclosure or cover should be removed or unzipped and pulled back when batteries are being charged. An accumulation of hydrogen gas could result in an explosion.

⚠ WARNING

- Only trained technicians should repair or service the charger. Contact your nearest Club Car distributor/dealer.
- Each charger should have its own dedicated 15 or 20 ampere separately protected (circuit breaker or fuse) single phase branch circuit, in accordance with all applicable electrical codes for the location.
- Connect the charger AC supply cord to a properly grounded, three-wire outlet of the proper voltage and frequency as shown on the charger.
- Do not use an adapter to plug the charger with a three-prong plug into a two-prong outlet. Improper connection of the equipment-grounding conductor can result in a fire or an electrical shock.
- An extension cord or electrical outlet must accept a three-prong plug. Extension cord should be a three-wire No. 12 AWG (American Wire Gauge) or no. 14 (British Standard Wire Gauge), and be as short as possible (no more than 12 feet (3.7 m)). The use of improper extension cord could result in fire or an electrical shock.
- Do not operate the charger if it has received a sharp blow, was dropped, or otherwise damaged in any way.
- Have worn, cut, or damaged power cords or wires replaced immediately.
- Do not use near fuels, grain dust, solvents, thinners, or other flammables. Chargers can ignite flammable materials and vapors.
- Do not expose to rain or any liquid. Keep the charger dry.
- Never push objects of any kind into the charger through cabinet slots. They may touch dangerous voltage points or cause an electrical short circuit that could result in fire or electrical shock.
- Do not connect a stationary charger to the receptacle if the charger cord, plug, or the vehicle receptacle is broken, damaged, or does not make a good electrical connection. Fire or personal injury can result. Have a qualified technician replace the parts.
- When the charger is on, the charger DC cord may be disconnected from the vehicle receptacle slowly. Jerking or pulling the DC cord out quickly could cause arcing and burning that could damage the plug and receptacle and could cause batteries to explode.
- Do not block or cover the charger ventilation slots. The slots provide ventilation and protect the charger from overheating.
- Do not allow clothing, blankets, or other material to cover the charger.
- Do not allow the charger to operate for more than 30 minutes at 19 or more amperes.
- Install surge arrestors on incoming AC power lines. Surge arrestors will help protect electrical components in the charger and on the vehicle from all but direct or close lightning strikes.

NOTE: Because the vehicle's onboard computer (OBC) has a storage charge feature that automatically checks and recharges the batteries as necessary every 15 days, the charger can remain plugged to the vehicle throughout the storage period.

At one hour and at two hours into the charge cycle, the charger will shut off in order to run a self-diagnostic program (ammeter will drop to zero). Charging will resume in a few moments (ammeter returns to previous rate of charge).

Each electric vehicle is supplied with a fully automatic battery charger as standard equipment. The AC cord to each charger is to be connected to a source capable of supplying 15 amperes minimum per charger.

To reduce the risk of electric shock, the battery charger must be grounded. The charger is equipped with an AC electric cord having an equipment-grounding conductor and a grounding type plug. The AC plug must be connected to an appropriate receptacle that is properly installed and grounded in accordance with the National Electrical Code and all local codes and ordinances. See the owner's manual supplied with the charger for specific operating instructions before using the charger.

The use of an extension cord with the charger should be avoided. If an extension cord must be used, use a three-conductor no. 12 AWG (American Wire Gauge) or no. 14 SWG (British Standard Wire Gauge), heavy-duty cord with ground, properly wired and in good electrical condition. Keep it as short as possible (no more than 12 feet (3.7 m)). Place all cords so they will not be stepped on, tripped over, or otherwise subject to damage or stress.

Ensure that the charger ventilation slots are unobstructed and that there is adequate ventilation.

CHARGING BATTERIES

▲ WARNING

- **Be sure all wire connections at the receptacle and the fuse link are clean and tight.**
- **Do not rock or bend the plug. To connect the charger plug to the vehicle receptacle, grasp the plug handle and push the plug straight into the receptacle (Figure 29, Page 48).**
- **Do not pull on the DC cord (Figure 30, Page 48). Do not twist, rock or bend the plug. To disconnect the charger plug from the vehicle receptacle, grasp the plug by the handle and pull the plug straight out of the receptacle.**
- **Do not connect a charger to the receptacle if the charger cord, plug, or the vehicle receptacle is broken, damaged in any manner, or does not make a good electrical connection. Fire or personal injury can result. Have it replaced by a qualified service person immediately.**
- **Failure to follow these instructions could result in damage to the charger cord, the plug, and (or) the vehicle receptacle.**
- **Do not use a charger if:**
 - **The plug is too loose or does not make a good connection.**
 - **The plug and receptacle feel hotter than normal during charge.**
 - **The plug pins or receptacle contacts are bent or corroded.**
 - **The plug, receptacle, or cords are cut, worn, have any exposed wires or are damaged in any way.**
- **Using the charger with any of the above symptoms could result in a fire, property damage, personal injury, or death.**

NOTE: *When temperatures fall below 65 °F (18.3 °C), batteries charged in unheated areas should be placed on charge as soon as possible after use. Batteries are warmest immediately after use, and cold batteries require more time to fully charge.*

Insert the charger DC plug into the vehicle receptacle. The charger will turn on two to ten seconds later (**Figure 29, Page 48**).

When inserting the DC plug, align the raised guide on the plug with the guide slot in the receptacle and push straight in slowly.

Club Car battery chargers interact with the vehicle onboard computer. The computer records the amount of energy consumed during vehicle use. While the charger is plugged in, the vehicle's control circuit is locked out, preventing operation of the vehicle, as well as the possibility of consequent damage to the charger and the vehicle.

Once the lockout is actuated, the charger turns on. The onboard computer then records the amount of energy being returned to the batteries. When the optimum amount of energy needed to replenish the batteries is returned, the charger will shut off. The control circuit lockout remains activated until the charger plug is disconnected from the vehicle.

Only Club Car PowerDrive battery chargers are compatible with Precedent electric vehicles.

As long as the charger is allowed to shut off by itself, the batteries will be fully charged. Overcharging and undercharging will normally be prevented.

Batteries should be put on charge even if they have been used for only a short period (9 holes of golf or 10 minutes). The charger is automatic and will turn off when batteries are fully charged. If the charger does not seem to be operating properly, or if the batteries seem weak, contact your local Club Car distributor/dealer.

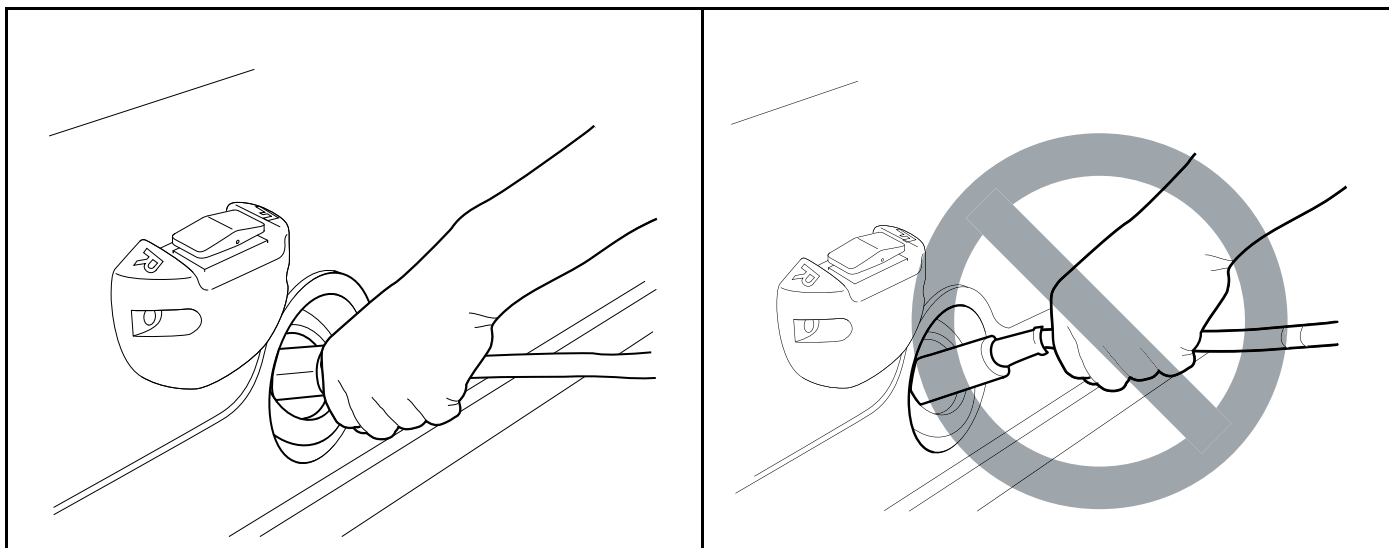

66

Figure 29 Correct Insertion of Charger DC Plug

67

Figure 30 Incorrect Removal of Charger DC Plug

PLUG AND RECEPTACLE

The charger cord, plug, and receptacle are wear items and should be inspected daily. Visually inspect them for cracks, loose connections, and frayed wiring; they must be replaced when worn or damaged. If charger plug or receptacle show signs of corrosion or the plug is difficult to insert or remove, the receptacle contacts and plug terminals should be cleaned with a good electrical contact cleaner or lightly sprayed with WD-40® brand spray lubricant. The plug should then be inserted and removed several times to ensure ease of insertion, ease of removal, and good electrical contact. **See following NOTE.**

NOTE: If the warning tag has been damaged or removed from the DC cord, have it replaced immediately.

SINGLE POINT WATERING SYSTEM (SPWS)

⚠ WARNING

- When replacing batteries in the Single Point Watering System, place the battery cap from the new replacement battery onto the used battery being removed from the car. Important safety warnings on the battery cap must remain with the battery after it has been removed from the car.

CAUTION

- Water the batteries only **AFTER** charging.
- Use the water deionizer equipment (CC P/N AM1240701) to water batteries with the SPWS.

WATERING BATTERIES WITH THE SPWS

Checking the Water Flow Rate

1. Connect the water hose with the built-in screen filter (2) to the water faucet (1) (**Figure 31**). See following **CAUTION**.

CAUTION

- Make sure the screen filter is clean.
 - Do not use a longer garden hose than provided with the System (20 feet), as a decrease in water pressure could overflow the batteries and damage the refill system.
2. Before screwing the hose-end assembly (3) onto the opposite end of the water hose, check the screen filter (4) inside the end of the assembly to make sure it is clean (**Figure 31**).
 3. Connect the purger (5) to the female coupler (8) on the end of the hose-end assembly (**Figure 32**).

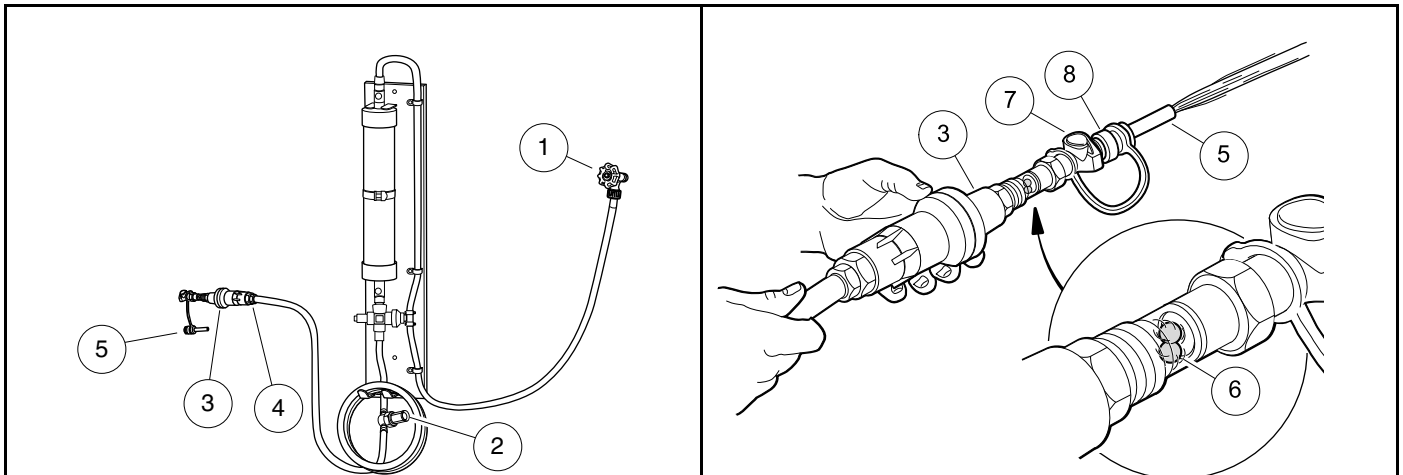

68

Figure 31 Connecting Hose with Filter to Water Source

69

Figure 32 Checking the Water Flow Rate

4. Completely open the water faucet until the water flows out of the hose-end assembly (3), and note the movement of the red flow indicator balls (6). See following **NOTE**.

NOTE: The water flow rate must be at least two gallons-per-minute for the SPWS to function properly.

This step also eliminates any trapped air from the water hose.

5. Check the water quality light on the deionizer to make sure the light is green in color, indicating acceptable water quality. If the light indicates unacceptable water quality, the cartridge must be replaced.
6. After ensuring adequate water flow rate and water quality, press the grey button (7) on the end of the female coupler (8) to disconnect the purger from the pressure regulator.

Refilling the Batteries

1. Locate the battery fill coupling (9) on the driver side of the battery compartment, remove the dust cover (10) from the male connector (**Figure 33**), and connect the hose-end assembly (3) (**Figure 34**). The water flow will begin immediately.

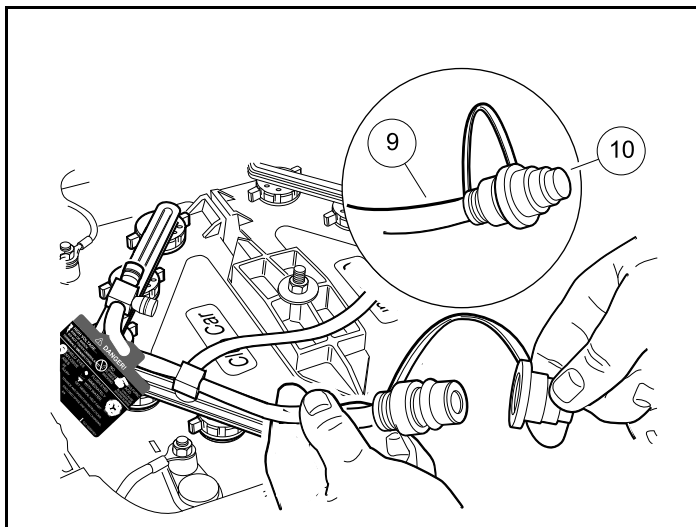

70

Figure 33 Dust Cap

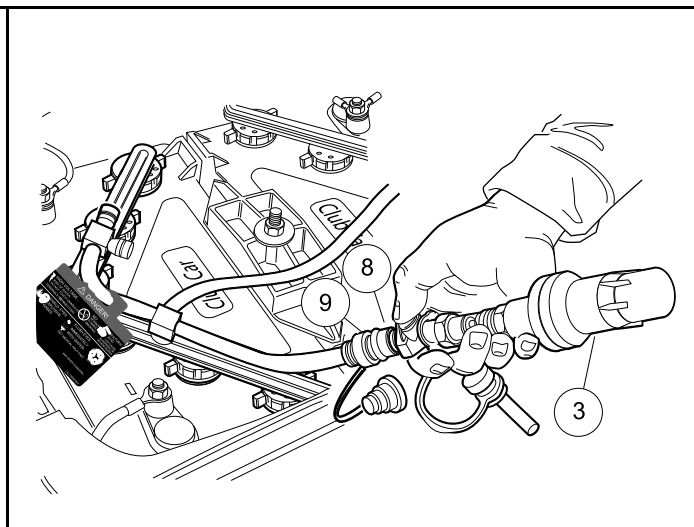

71

Figure 34 Connecting Hose-end Assembly to Battery Fill Connector

2. The red flow indicator balls should swirl, indicating that the batteries are being filled. **See following CAUTION.**

CAUTION

- **If at any time water overflows from the batteries, immediately stop the refill process, disconnect the pressure regulator from the battery fill coupling, and call for service.**
3. When the red flow indicator balls stop moving, immediately press the grey button to disconnect the hose-end assembly from the battery fill coupling (9), and squeeze the dust cover (10) to lightly secure it to the male connector of the battery fill coupling (**Figure 33**).
 4. Place the battery fill coupling into the space between the battery bucket and the car body. Leaving the fill coupling on top of the battery bank or tucked between the batteries and the battery bucket can result in coupling damage.
 5. Turn the water faucet off when finished filling the vehicle(s).

BATTERY – GASOLINE VEHICLES

See General Warnings on page 11.

⚠ DANGER

- **Battery – Explosive gases! Do not smoke. Keep sparks and flames away from the vehicle and service area. Ventilate when charging or operating vehicle in an enclosed area. Wear a full face shield and rubber gloves when working on or near batteries.**
- **Tools, wires, and metal objects can cause sparks when shorted across a battery.**
- **Follow all instructions carefully when working with batteries.**
- **Charge battery in a well-ventilated area only.**
- **Battery – Poison! Contains acid! Causes severe burns. Avoid contact with skin, eyes, or clothing.**
Antidotes:
 - **External: Flush with water. Call a physician immediately.**
 - **Internal: Drink large quantities of milk or water followed with milk of magnesia or vegetable oil. Call a physician immediately.**
 - **Eyes: Flush with water for 15 minutes. Call a physician immediately.**

⚠ WARNING

- **Do not jump start a dead battery using another battery and jumper cables.**

The battery in the Club Car gasoline vehicle is a 12-volt, low maintenance battery that requires infrequent watering (**Figure 35**).

Any corrosion around the positive (+) or negative (–) terminals should be washed off with a solution of baking soda and water (1 cup (237 mL) per gallon (3.8 L) of water). Rinse solution off the battery. Do not allow this solution to enter battery. Be sure terminals are tight. Let the terminals dry and then spray them with Battery Terminal Protector Spray (CC P/N 1014305). **See Connecting the Battery – Gasoline Vehicles on page 13. See preceding and following WARNINGS.**

⚠ WARNING

- **If battery wire terminals are damaged or corroded, replace or clean them as necessary. Failure to do so may cause them to overheat during operation and could result in fire, property damage, or personal injury.**

Be sure battery clamp is properly tightened. Tighten to 144 in-lb (16 N·m). A loose battery clamp may allow the battery to become damaged from vibration or jarring.

If battery appears weak, have it charged by a trained technician. The battery should never be left discharged any longer than absolutely necessary (do not leave discharged overnight).

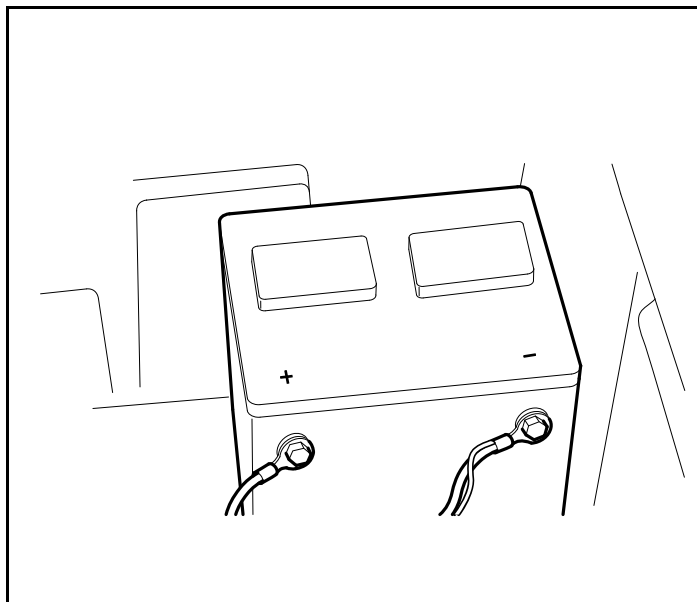

72

Figure 35 Gasoline Vehicle Battery

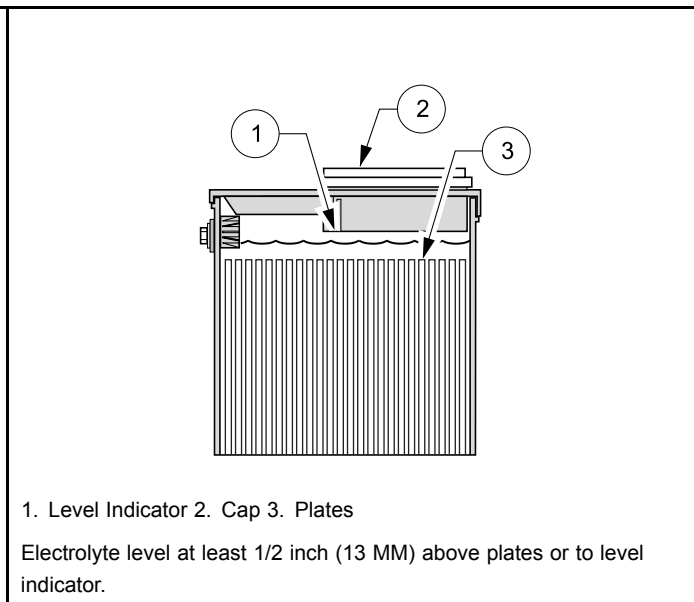

1. Level Indicator 2. Cap 3. Plates

Electrolyte level at least 1/2 inch (13 MM) above plates or to level indicator.

22

Figure 36 Electrolyte Level for Battery

ENGINE OIL – GASOLINE VEHICLES

ENGINE OIL LEVEL CHECK

1. Remove the oil level dipstick from the oil filler tube, and wipe oil off dipstick (1) (**Figure 37**). **See following CAUTION.**

CAUTION

- **Do not remove dipstick while engine is running.**
2. Check oil by fully inserting the dipstick into the oil filler tube (2) and immediately removing it.
 3. If the oil level is at or below the low level mark on the dipstick gauge, add oil until the level is between low and full levels (safe level) (3).
 4. Insert the dipstick into the oil filler tube. **See following NOTE.**

NOTE: Properly recycle or dispose of used oil in accordance with the environmental laws and regulations for your area.

Even though the low oil warning light on the dash should warn you if your oil becomes low, engine oil level should be checked monthly. Vehicle should be on a level surface when checking oil. Do not overfill with oil.

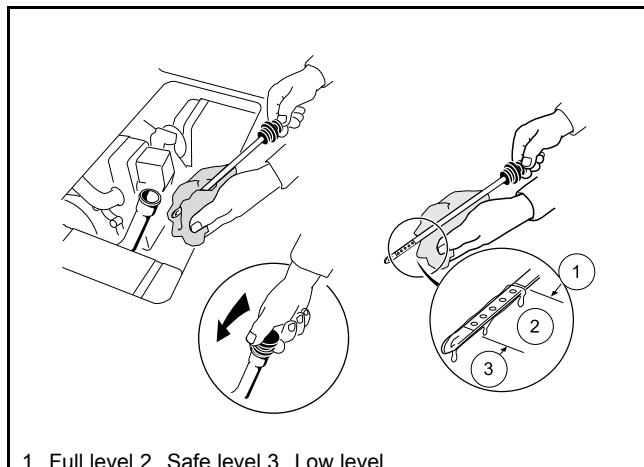

23

Figure 37 Engine Oil Level Check

ENGINE OIL AND FILTER CHANGE

Engine oil and oil filter should be changed after the first 100 hours of operation. After that, they should be changed every 200 hours of operation or annually, whichever comes first.

1. Turn the key switch to the OFF position, then remove the key. Place the Forward/Reverse handle in the NEUTRAL position. Chock the front wheels.
2. Access the engine compartment.
3. Disconnect battery and spark plug wire(s). **See Disconnecting the Battery – Gasoline Vehicles on page 13.**
4. Position a pan designed for oil changes under the front drain plug (**Figure 38**).

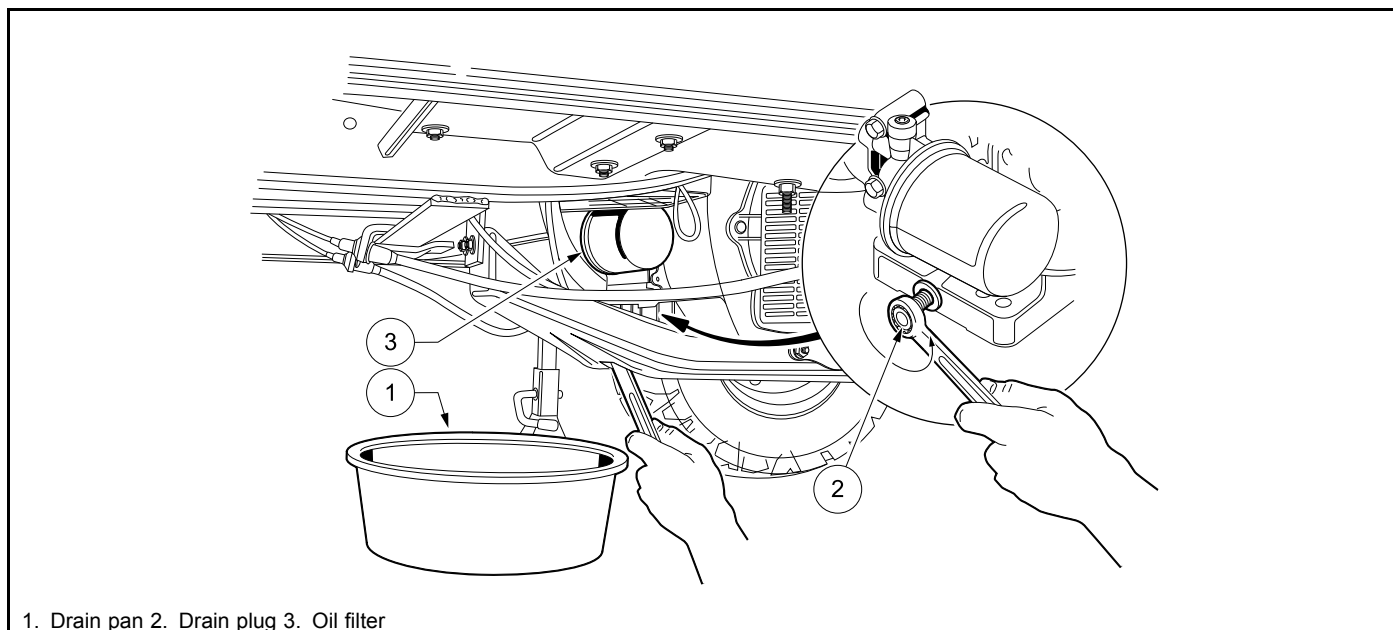

1. Drain pan 2. Drain plug 3. Oil filter

²⁵
Figure 38 Engine Oil Drain Plug and Pan

5. Use a 14 mm socket or wrench to remove the drain plug, turning it counterclockwise, and allow the engine oil to drain into the pan. **See following WARNING.**

⚠ WARNING

- **Do not attempt to change engine oil when the engine is hot or even warm. Engine oil can cause skin burns.**
 - **Wear safety glasses or approved eye protection when servicing the vehicle. Wear rubber gloves when handling oil drain plug, oil filter, and oil drain pan.**
6. Clean the oil drain plug threads with solvent to remove oil and oil residue. Make sure that the compression washer remains on the drain plug.
 7. Use a 14 mm socket or wrench and replace the front oil drain plug, turning it clockwise, and tighten to 18 ft-lb (24.4 N·m).
 8. Relocate the oil drain pan to a position under the engine oil filter (**Figure 38**).
 9. Remove the engine oil filter, turning it counterclockwise, allowing the residual oil in the filter port and filter to drain into the oil drain pan (**Figure 39**). **See following NOTE.**

NOTE: An oil drip guard can be used to prevent excess oil from dripping into the engine base plate. Use an empty quart (one liter) container and cut the bottom off at an angle, then slide the open area of the container up and under the oil filter prior to removing. Position the port of the plastic container so oil will be directed into the oil pan. Or, make a drip guard by folding a piece of cardboard, thin metal, or plastic under the oil filter forming a channel to direct the filter port oil into the drain pan.

Dispose of used oil according to the environmental laws and regulations for your area.



26

Figure 39 Remove Engine Oil Filter

10. Use a clean rag and wipe the oil filter mounting bracket surface clean where the oil filter gasket seats.
11. Coat new oil filter gasket with clean engine oil, Install the oil filter onto the engine oil filter port (**Figure 40**).

NOTE: Use only Club Car oil filters (CC P/N 1016467) designed for this engine.

12. Hand tighten 2/3 to 3/4 turn after filter gasket contacts mounting surface.
13. Remove the dipstick and add engine oil into the dipstick port. With filter change, the engine requires 38 ounces (1.12 liters) of oil per change. Refer to oil viscosity guidelines for selection of oil grade (**Figure 41**). **See following Caution.**

CAUTION

- Do not exceed recommended oil capacity. Doing so will decrease engine performance or result in damage to the engine.
14. Replace the dipstick
 15. Connect battery and spark plug wire(s). **See Connecting the Battery – Gasoline Vehicles on page 13.**
 16. With the Forward/Reverse handle in the NEUTRAL position, run engine for 3 minutes and check for leaks. Observe both the drain plug and the oil filter from under the vehicle and watch for oil leaks. If filter leaks, tighten additional 1/4 turn and retest, if oil drain plug leaks, re-torque and retest.
 17. Remove the dip stick and check the engine oil as a final step. Replace the dip stick.

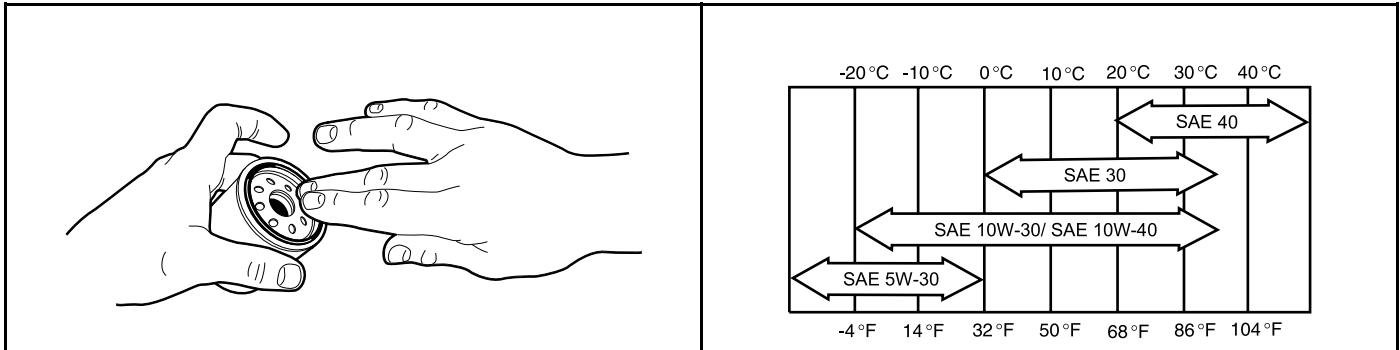

27

Figure 40 Coat Oil Filter Rubber Seal

213

Figure 41 Oil Viscosity Chart

FUELING INSTRUCTIONS – GASOLINE VEHICLES

See General Warnings on page 11.

⚠ DANGER

- Turn the key switch to the OFF position before fueling.
- Do not pour fuel into the fuel tank when the engine is hot or while it is running.
- Be sure the fuel tank ground wire, located next to the fuel shut-off valve, is properly connected before fueling the vehicle.
- To avoid electric arc caused by static electricity, the fuel storage/pumping device must be grounded. If the pump is not grounded, the vehicle must be grounded to the pump before and during the fueling operation.
- If the vehicle has an all-weather enclosure installed, be sure the fuel tank is properly vented as shown (Figure 25, Page 34).
- To avoid the possibility of fire, clean up any spilled fuel before operating the vehicle.

⚠ CAUTION

- Use unleaded gasoline only.
- Whenever possible, avoid using oxygenated and blended fuels.

CAUTION CONTINUED ON NEXT PAGE

⚠ CAUTION

- Do not use any fuel with an alcohol content that exceeds 10% by volume (such as E15 and E85). Ethanol is an alcohol that readily absorbs moisture, causing corrosion of fuel system components. It also damages neoprene and other plastic and rubber components. Use of these fuels in this vehicle will void the warranty.
- To allow for expansion, do not fill higher than 2.54 cm (one inch) from the top of the fuel tank. Avoid spilling fuel.

NOTE: Vehicles to be stored for extended periods should be prepared for storage as instructed. See *Preparing the Gasoline Vehicle for Extended Storage* on page 33.

1. Turn the key switch to the OFF position.
2. Lift and remove seat bottom.
3. The fuel tank is located on driver side of vehicle. Remove fuel cap and fill the fuel tank with fresh unleaded gasoline only. See preceding **DANGER** and **CAUTION**.
4. Replace fuel cap on tank. Ensure that cap is tightened securely.
5. Replace seat bottom.

CLEANING THE VEHICLE

Club Car Precedent vehicles are equipped with hand-washable front and rear bodies. Use only commercially available automotive cleaners with a sponge or soft cloth for normal cleaning. A garden hose at normal residential water pressure is adequate.

The manufacturer does not recommend any type of pressure washing or steam cleaning. Such a process will expose electrical components to moisture. Moisture entering electrical components can result in water damage and subsequent component failure.

Use non-abrasive wax products. Battery acid, fertilizers, tars, asphalt, creosote, paint, or chewing gum should be removed immediately to prevent possible stains. See following **CAUTION**.

CAUTION

- Use of leveling or rubbing compounds will permanently dull finish of vehicle.
- Do not apply wax products to the black plastic material of the front and rear underbody, the front bumper, or the textured area of the rear beauty panel marked "NO STEP." Wax will cause these surfaces to become discolored.

The seats of the vehicle will last longer with proper cleaning. Use a solution of 10% liquid soap and warm water applied with a soft cloth. For imbedded dirt, a soft bristle brush may be used. For heavy soiling, difficult stains or scratches, blemishes, or other body damage, see the appropriate maintenance and service manual.

NOTE: Dispose of waste water properly.

ACCESSORIES

There is a complete line of accessory equipment available from Club Car and our dealers/distributors. You can obtain the name and phone number of your closest Club Car contact by visiting our web site at www.clubcar.com and clicking the "Dealer Locator" link.

Care should be taken that these accessories are properly installed by trained technicians, and that they are used in the manner for which they were designed. See following **WARNING**.

WARNING

- Windshields and weather-proof enclosures will not protect occupants from flying objects (golf balls, etc.).

SUBSEQUENT OWNER REGISTRATION

In the event a vehicle is bought as a used vehicle, we strongly urge the new owner to register the vehicle with Club Car. This will enable us to contact you if the need arises. Please send your name, address, and serial number(s) of the vehicle(s) to Club Car, LLC, P.O. Box 204658, Augusta, Georgia 30917-4658, Attention: Vehicle Registration.

PRECEDENT FOUR-PASSENGER VEHICLE

The Precedent four-passenger vehicle is designed to provide a smooth and comfortable ride for four passengers, and is offered in both gasoline and electric power configurations. This owner's manual should be read thoroughly prior to operating the vehicle.

The Precedent four-passenger vehicle should be driven and maintained as stated in this owner's manual with the following additions:

WARNING

- Vehicle should be driven at slower speeds when four persons are in the vehicle.
- Passengers should hold on to hand holds or hand rails at all times. See page 9. Driver should keep both hands on the steering wheel while vehicle is moving.
- Do not leave children unattended on the rear seat while vehicle is moving.
- No more than four persons should be on the vehicle at one time.

MAINTENANCE

Refer to pages 35 through 40 for Periodic Service and Lubrication Schedules. **See following NOTE.**

***NOTE:** If the vehicle is constantly hauling heavy loads, the preventive maintenance procedures should be performed more often than recommended in the service and lubrication schedules.*

ACCESSORY ONBOARD CHARGER

An onboard charger, which is installed under the rear seat, is available for the Precedent four-passenger electric vehicle. The charger should be plugged into a properly grounded outlet. The AC line to which the charger is to be connected must be of the proper AC input voltage for the charger and must be capable of supplying sufficient current. See the battery charger owner's manual supplied with the battery charger for specific operating instructions and specifications before using the charger. **See following WARNING and CAUTION.**

WARNING

- Each charger should have its own dedicated 15 or 20 ampere separately protected (circuit breaker or fuse) single phase branch circuit, in accordance with all applicable electrical codes for the location.

CAUTION

- Before charging batteries, turn off all accessories on all vehicles.
- If using an onboard charger, be sure the AC plug is unplugged from the outlet before attempting to drive the vehicle.
- Be sure the AC cord is properly wound up on the reel before driving the vehicle.
- Study all general information and WARNING, CAUTION, and NOTE statements in the Battery Charger section on page 46.

VEHICLE SPECIFICATIONS

SPECIFICATIONS	TWO-PASSENGER ELECTRIC VEHICLE	TWO-PASSENGER GASOLINE VEHICLE	FOUR-PASSENGER ELECTRIC VEHICLE	FOUR-PASSENGER GASOLINE VEHICLE
POWER SOURCE				
Drive motor: Direct drive, 48 volts DC, shunt-wound, 3.1 hp	.		.	
Transaxle: Double reduction helical gear with 12.3:1 direct drive axle	.		.	
Electrical system: 48 volts DC, reduced speed reverse	.		.	
Batteries: High capacity, deep cycle	.		.	
Charger: Automatic, 48-volt; UL and CSA listed	.		.	
Engine: 4-cycle OHV, 351 cc, 11.5 maximum HP@3600 RPM (per SAE J 1940/1349), single-cylinder, air-cooled, with pressure lubrication system		.		.
Fuel system: Side-draft carburetor with float bowl, fixed jets, fuel filters, and impulse fuel pump		.		.
Governor: Automatic ground-speed sensing, internally geared in unitized transaxle		.		.
Ignition: Transistor electronic ignition with electronic RPM limiter		.		.
Unitized transaxle: Fully synchronized forward and reverse with neutral and reduced speed reverse (11.8:1 forward, 17.1:1 reverse)		.		.
Torque converter: Automatic, variable-speed, dry type		.		.
Electrical system: 12 volt, 500 cca at 0 °F (-17.8 °C), 650 at 32 °F (0 °C). 105-minute reserve capacity and 35-amp charging capacity		.		.
STEERING/SUSPENSION/BRAKES				
Steering: Self-adjusting rack and pinion
Suspension: Front and rear tapered mono-leaf springs with dual hydraulic shocks
Brakes: Dual rear wheel self-adjusting brakes with cast iron drums and single brake pedal with automatic-release park brake
BODY/CHASSIS				
Frame/Chassis: Aluminum and composite
Front and rear body: Dupont Surlyn© Reflections
Body finish: High-gloss molded-in color
Tires: 18 x 8.5 – 8 tubeless, 4 ply rated

Vehicle Specifications

SPECIFICATIONS	TWO-PASSENGER ELECTRIC VEHICLE	TWO-PASSENGER GASOLINE VEHICLE	FOUR-PASSENGER ELECTRIC VEHICLE	FOUR-PASSENGER GASOLINE VEHICLE
DIMENSIONS/WEIGHT				
Overall length	91.5 in. (232 cm)	91.5 in. (232 cm)	104 in. (264 cm)	104 in. (264 cm)
Overall width	47.25 in. (120 cm)	47.25 in. (120 cm)	47.25 in. (120 cm)	47.25 in. (120 cm)
Overall height (with canopy)	68.5 in. (174 cm)	68.5 in. (174 cm)	71 in. (180 cm)	71 in. (180 cm)
Overall height (at steering wheel)	48.0 in. (122 cm)	48.0 in. (122 cm)	48.0 in. (122 cm)	48.0 in. (122 cm)
Wheelbase	65.5 in. (166 cm)	65.5 in. (166 cm)	65.5 in. (166 cm)	65.5 in. (166 cm)
Ground clearance	4.5 in. (11 cm)	4.5 in. (11 cm)	4.5 in. (11 cm)	4.5 in. (11 cm)
Front wheel tread	34.5 in. (88 cm)	34.5 (88 cm)	34.5 in. (88 cm)	34.5 (88 cm)
Rear wheel tread	38.6 in. (98 cm)	38.6 in. (98 cm)	38.6 in. (98 cm)	38.6 in. (98 cm)
Weight (standard electric vehicle with canopy, with batteries) For vehicles with six 8-volt batteries, add 54 lb. (24.5 kg).	855 lb. (388 kg)		970 lb. (440 kg)	
Weight (standard gasoline vehicle with canopy, with battery, without fuel)		651 lb. (295 kg)		768 lb. (348 kg)
Forward speed	12-15 mph (19-24 km/h)			
Curb clearance circle (diameter)	17 ft - 4 in. (528 cm)	17 ft - 4 in. (528 cm)	17 ft - 4 in. (528 cm)	17 ft - 4 in. (528 cm)
Standard seating capacity	2	2	4	4
LIQUID CAPACITIES				
Transaxle	22 oz. (.67 liters)		22 oz. (.67 liters)	
Engine crankcase (without filter)		32 oz. (.95 liter)		32 oz. (0.95 liter)
Engine crankcase (with filter)		38 oz. (1.12 liters)		38 oz. (1.12 liters)
Unitized transaxle		27 oz. (0.8 liter)		27 oz. (0.8 liter)
Fuel tank		6.7 gallons (25.4 liters)		6.7 gallons (25.4 liters)
TIRE PRESSURE				
Front and rear	18-20 psi (1.24-1.38 bars)	12-14 psi (0.83-0.96 bars)	18-20 psi (1.24-1.38 bars)	18-20 psi (1.24-1.38 bars)
NOISE AND VIBRATION				
Drive-by noise level to operator Test method: EN 12053:2001	68.5 dBA Uncertainty: 2 dBA	70.9 dBA Uncertainty: 2 dBA	68.5 dBA Uncertainty: 2 dBA	70.9 dBA Uncertainty: 2 dBA
Vibration at driver's seat Test method: EN 13059:2002	0.6 m/s ² Uncertainty: 0.114 m/s ²	0.8 m/s ² Uncertainty: 0.096 m/s ²	0.8 m/s ² Uncertainty: 0.072 m/s ²	0.8 m/s ² Uncertainty: 0.087 m/s ²

WARRANTIES

LIMITED LIFETIME WARRANTY FOR PRECEDENT™ BY CLUB CAR®

WARRANTY: CLUB CAR, LLC, (CLUB CAR) hereby warrants its new Precedent golf car purchased from CLUB CAR or an authorized distributor, dealer, or agent shall be free from defects in material and workmanship under normal use and service for the period as stated in years below, as terms are defined herein, and subject to the provisions, limitations and exclusions contained in this warranty.

	i2L	i2	V4
VEHICLE MAIN FRAME	LIFETIME*		
SUSPENSION defined as Steering Gearbox, Steering Column, Shocks, and Leaf Springs.	4	4	4
MAJOR ELECTRONICS defined as Onboard Computer (OBC), Solid State Speed Controller, and Battery Charger.	4	4	4
DEEP CYCLE BATTERY Four Years or 1000 Rounds or 20,000 Energy Units (EU's) as recorded by the OBC, whichever first occurs.	4	4	4
PREMIUM DEEP CYCLE BATTERY Four Years or 25,000 Energy Units (EU's) as recorded by the OBC, whichever first occurs.	4	4	4
PEDAL GROUP defined as Pedal Group Mechanical Assembly, Brake Cluster Assemblies, and Brake Cables.	4	4	4
SEATS defined as Seat Bottom, Seat Back, and Arm Rest.	4	4	4
CANOPY SYSTEM defined as Canopy, Rear Canopy Supports, Drainage System and Structural Accessory Module.	4	4	4
POWERTRAIN defined as Gasoline Engine, Electric Motor, Gasoline and Electric Transaxle, Starter Generator, Air Intake, Exhaust System, and Torque Converter (Drive and Driven).	3	3	3
BODY GROUP defined as Beauty Panels, and Front and Rear Underbody.	3	3	3
ALL REMAINING COMPONENTS defined as Solenoid, MCOR, GCOR, Limit Switches, Voltage Regulator, F&R Switch, and Options, and Accessories supplied by CLUB CAR, including components not specified otherwise.	2	2	2

IF THE WARRANTY REGISTRATION FORM IS NOT COMPLETED AND RETURNED TO CLUB CAR AT THE TIME OF THE ORIGINAL RETAIL SALE, PURCHASER MUST PROVIDE PROOF OF DATE OF PURCHASE WITH ANY WARRANTY CLAIM.

EXCLUSIONS:

Excluded from any CLUB CAR warranty is damage to a golf car or component resulting from a cause other than a defect including poor maintenance, neglect, abuse, accident & collision, maintenance adjustments, unreasonable or unintended strain or use, improper installation of accessories, installation of parts or accessories that are not original equipment, non-approved alteration, and acts of God. Also excluded from any CLUB CAR warranty are all fuses, filters, decals (except safety decals), lubricants, routine wear items such as the charger plug and receptacle, brake shoes, belts, brushes, bushings, drive buttons, cosmetic deterioration, and items which deteriorate, fade or fail due to exposure or ordinary wear and tear.

Specific to the deep cycle battery, the provisions of this limited warranty shall not apply to failure due to:

- 1) Abuse such as overcharging, undercharging, improper fluid levels, loose wiring, or rusted or corroded hardware;
- 2) Lack of proper maintenance as outlined in the vehicle owner's manual;
- 3) Damages caused by improper installation of the battery;
- 4) Neglect, breakage, freezing, fire, explosion, wreckage, the addition of any chemical, or the operation of the battery in an uncharged condition (below half charge 1.200 specific gravity); the installation of the batteries in reverse or recharging in reverse, breakage of containers, covers, or terminal post, or batteries used in applications for which they were not designed.
- 5) A battery damaged by a defective charger.

Transportation expenses for warranty services are also excluded from this warranty.

VOIDING OF WARRANTY:

THIS AND ANY OTHER WARRANTY SHALL BE VOID IF THE GOLF CAR IS ABUSED OR USED IN AN UNINTENDED MANNER OR SHOWS INDICATIONS THAT IT HAS BEEN ALTERED IN ANY WAY, INCLUDING, BUT NOT LIMITED TO, MODIFICATION OF THE SPEED GOVERNOR, BRAKING SYSTEM, STEERING, TRANSAXLE, OR OTHER OPERATING SYSTEMS OF THE CAR TO CAUSE IT TO PERFORM OUTSIDE CLUB CAR SPECIFICATIONS. THE WARRANTY IS LIKEWISE VOID IF THE CAR INVOLVED SHOWS INDICATIONS THAT REASONABLE OR NECESSARY MAINTENANCE AS OUTLINED IN THE OWNER'S MANUAL AND MAINTENANCE AND SERVICE MANUAL WAS NOT PERFORMED AT THE TIME AND IN THE MANNER SPECIFIED IN SUCH MANUALS.

SOLE REMEDY:

CLUB CAR's liability under this limited warranty, or in any action whether based upon warranty, contract, negligence, strict product liability or otherwise, shall be the repair or replacement, at CLUB CAR's option, of the golf car or component thereof that CLUB CAR deems to be defective. Replacement shall mean furnishing, during the applicable limited warranty period, a new golf car or factory-reconditioned vehicle or component thereof that is identical or reasonably equivalent to the warranted product or component at no cost to the purchaser. Repair shall mean remedying a defect in the golf car or component thereof at no cost to the purchaser during the applicable limited warranty period. If CLUB CAR elects to repair the golf car, it may provide factory-reconditioned parts or components. All parts and components replaced under warranty shall become the property of CLUB CAR.

DISCLAIMER:

THIS LIMITED WARRANTY IS EXCLUSIVE. CLUB CAR MAKES NO OTHER WARRANTY OF ANY KIND, EXPRESSED OR IMPLIED. ANY IMPLIED WARRANTIES OF MERCHANTABILITY OR FITNESS FOR A PARTICULAR PURPOSE WHICH EXCEED THE OBLIGATIONS OR TIME LIMITS STATED IN THIS WARRANTY ARE HEREBY DISCLAIMED BY CLUB CAR AND EXCLUDED FROM THIS WARRANTY. THE PURCHASER AND CLUB CAR EXPRESSLY AGREE THAT THE SOLE REMEDY OF THE REPLACEMENT OR REPAIR OF THE DEFECTIVE GOLF CAR OR COMPONENT THEREOF IS THE SOLE REMEDY OF THE PURCHASER. CLUB CAR MAKES NO OTHER REPRESENTATION OR WARRANTY OF ANY KIND, AND NO REPRESENTATIVE, EMPLOYEE, DISTRIBUTOR OR DEALER OF CLUB CAR HAS THE AUTHORITY TO MAKE OR IMPLY ANY REPRESENTATION, PROMISE OR AGREEMENT, WHICH IN ANY WAY VARIES THE TERMS OF THIS WARRANTY.

In the event that another pre-printed warranty document and/or certificate offered by or through Club Car at the time of sale of this vehicle (each an "Additional Warranty Document") is deemed to conflict with the limitations or exclusions contained herein, the limitations and exclusions contained herein shall continue to apply with respect to both this limited warranty statement and, to the maximum extent permitted by law, to each Additional Warranty Document.

NO CONSEQUENTIAL DAMAGES:

IN NO EVENT SHALL CLUB CAR BE LIABLE FOR ANY INCIDENTAL OR CONSEQUENTIAL DAMAGES INCLUDING, BUT NOT LIMITED TO, LOSS RELATED TO PROPERTY OTHER THAN THE GOLF CAR, LOSS OF USE, LOSS OF TIME, INCONVENIENCE, OR ANY OTHER ECONOMIC LOSS.

Some states allow neither limitation on the duration of an implied warranty nor exclusions or limitation of incidental or consequential damages. Therefore, the above limitations or exclusions may not apply to you.

This warranty gives you specific legal rights, and you may also have other rights, which vary from state to state.

INFORMATION:

For further information contact WARRANTY SERVICES, CLUB CAR, LLC, P.O. Box 204658, Augusta, Georgia 30917-4658, U.S.A., 706-863-3000.

WARRANTY TRANSFER:

The original owner shall have the right to transfer any remaining warranty coverage to one subsequent purchaser only. In order for the original owner to transfer any remaining warranty coverage to a subsequent purchaser, the vehicle must be re-registered by an Authorized Club Car Distributor or Dealer with the Warranty Department at Club Car, LLC. Such transfer must take place within the first three years of the original in service date of the vehicle. *The Limited Lifetime section of the warranty coverage applies to the original purchaser or lessee only, and the subsequent purchaser will only have a four-year coverage period based on the original in service date. No transfers of any remaining warranty coverage shall be permitted by any subsequent purchasers.

WARNING:

Any modification or alteration of any golf car beyond factory specifications, including those that affect the weight distribution, stability, or speed of the golf car, can cause serious personal injury or death.

CALIFORNIA EMISSION CONTROL WARRANTY STATEMENT

YOUR WARRANTY RIGHTS AND OBLIGATIONS:

The California Air Resources Board (“CARB”) and Club Car, LLC (“CLUB CAR”) are pleased to explain the emission control system warranty on your 2009 and newer vehicle engine (the “emission warranty”). In California, new small off-road engines (“SORE”) must be designed, built and equipped to meet the State’s stringent anti-smog standards. CLUB CAR shall warrant the emission control system on the vehicle engine for the periods of time listed below provided there has been no abuse, neglect or improper maintenance of your small off-road engine.

Your emission control system may include parts such as the carburetor or fuel-injection system, the ignition system, the catalytic converter and related hoses, belts, connectors and other emission assemblies or components.

Where a warrantable condition exists, as defined herein, CLUB CAR will repair your vehicle engine at no cost to you including diagnosis, parts and labor.

MANUFACTURER’S WARRANTY COVERAGE:

This emission control system is warranted for two years from the vehicles’ date of purchase. If any emission-related part on your CLUB CAR SORE is defective, the part will be repaired or replaced by CLUB CAR.

OWNER’S WARRANTY RESPONSIBILITIES:

- As the vehicle engine owner, you are responsible for the performance of the required maintenance listed in your owner’s manual. CLUB CAR recommends that you retain all receipts covering maintenance on your vehicle engine, but CLUB CAR cannot deny warranty solely for the lack of receipts or for your failure to ensure the performance of all scheduled maintenance.

- As the vehicle engine owner, you should however be aware that CLUB CAR may deny you warranty coverage if vehicle engine or a part has failed due to abuse, neglect, improper maintenance or unapproved modifications.

- You are responsible for presenting vehicle engine to a CLUB CAR distribution center as soon as a problem exists. The warranty repairs should be completed in a reasonable amount of time, not to exceed 30 days. If you have any questions regarding your warranty rights and responsibilities, you should contact WARRANTY SERVICES, CLUB CAR, LLC, P.O. Box 204658, Augusta, Georgia 30917-4658, U.S.A., 1-706-863-3000.

CLUB CAR EXPLANATION OF EMISSION CONTROL WARRANTY:

1. WARRANTY:

CLUB CAR warrants to the ultimate purchaser and each subsequent purchaser that the SORE and related emissions equipment is designed, built and equipped so as to conform with all applicable California environmental emission regulations; and free from defects in materials and workmanship that cause the failure of a warranted part to be identical in all material respects to that part as described in CLUB CAR’s application for certification with CARB. The warranty period begins on the date the engine or equipment is delivered to an ultimate purchaser or first placed into service. The warranty period is two years from the date of purchase.

2. COVERAGE:

Subject to certain conditions and exclusions as stated below, the warranty on emission-related parts is as follows:

(1) Any warranted part that is not scheduled for replacement as required maintenance in the written instructions supplied, is warranted for the warranty period stated above. If the part fails during the period of warranty coverage, the part will be repaired or replaced by CLUB CAR according to subsection (4) below. Any such part repaired or replaced under warranty will be warranted for the remainder of the original warranty period.

(2) Any warranted part that is scheduled only for regular inspection in the written instructions supplied is warranted for the warranty period stated above. Any such part repaired or replaced under warranty will be warranted for the remaining original warranty period.

(3) Any warranted part that is scheduled for replacement as required maintenance in the written instructions supplied is warranted for the period of time before the first scheduled replacement date for that part. If the part fails before the first scheduled replacement, the part will be repaired or replaced by CLUB CAR according to subsection (4) below. Any such part repaired or replaced under warranty will be warranted for the remainder of the period prior to the first scheduled replacement point for the part.

(4) Repair or replacement of any warranted part under the warranty provisions herein must be performed at a warranty station* at no charge to the owner.

(5) Notwithstanding the provisions herein, warranty services or repairs will be provided at all of our distribution centers that are franchised to service the subject engines or equipment.

(6) The engine or equipment owner will not be charged for diagnostic labor that is directly associated with diagnosis of a defective, emission-related warranted part, provided that such diagnostic work is performed at a warranty station*.

(7) CLUB CAR is liable for damages to other engine or equipment components proximately caused by a covered failure under warranty of any warranted part.

(8) Throughout the engine or equipment warranty period stated above, CLUB CAR will maintain a supply of warranted parts sufficient to meet the expected demand for such parts.

(9) Any replacement part may be used in the performance of any warranty maintenance or repairs and must be provided without charge to the owner. Such use will not reduce the warranty obligations of CLUB CAR.

(10) Add-on or modified parts that are not exempted by the Air Resources Board may not be used. The use of any non-exempted add-on or modified parts by the ultimate purchaser will be grounds for disallowing a warranty claims. CLUB CAR will not be liable to warrant failures of warranted parts caused by the use of a non-exempted add-on or modified part.

*CLUB CAR, its authorized dealers, or a service agency approved by CLUB CAR.

ITEMS COVERED BY THIS WARRANTY:

The repair or replacement of any warranted part otherwise eligible for warranty coverage may be excluded from such warranty coverage if CLUB CAR demonstrates that the engine or equipment has been abused, neglected, or improperly maintained, and that such abuse, neglect, or improper maintenance was the direct cause of the need for repair or replacement of the part. That notwithstanding, any adjustment of a component that has a factory installed, and properly operating, adjustment limiting device is still eligible for warranty coverage. The following emission warranty parts list are covered:

SYSTEMS COVERED PARTS DESCRIPTION

Fuel Metering Carburetor assembly, fuel injection pump, fuel injection nozzle, fuel regulator Exhaust Catalytic Converter, Exhaust Manifold Air Induction Air filter housing, air filter*, crankcase breather tube Ignition Flywheel magneto, ignition pulse generator, ignition coil assembly, ignition control module, spark plug cap, spark plug* Positive Crankcase Ventilation (PCV) System PCV valve, oil filler cap Evaporative System Fuel Tank, Fuel Cap, Fuel Lines, Fuel Line Fittings, Clamps, Pressure Relief Valves, Purge Valves, Vapor Hoses, Carbon Canister, Canister Mounting Brackets, Carbon Canister Purge Port Connector Misc. Parts Belts, hosing, tubing, fittings, seals, gaskets, clamps, and switches associated with the above systems.

Emission-related parts will vary between vehicles; therefore, certain vehicles may not include all of the listed parts or may include equivalent parts.

3. VOIDING OF WARRANTY:

THIS AND ANY OTHER WARRANTY SHALL BE VOID IF THE VEHICLE IS ABUSED OR USED IN AN UNINTENDED MANNER OR SHOWS INDICATIONS THAT IT HAS BEEN ALTERED IN ANY WAY, INCLUDING, BUT NOT LIMITED TO, MODIFICATION OF THE SPEED GOVERNOR, BRAKING SYSTEM, STEERING, TRANSAXLE, OR OTHER OPERATING SYSTEMS OF THE VEHICLE TO CAUSE IT TO PERFORM OUTSIDE CLUB CAR SPECIFICATIONS.

4. HOW TO MAKE A WARRANTY CLAIM:

To make a warranty claim under this limited warranty, you must present the vehicle or defective component to an authorized CLUB CAR dealer or send the defective component, freight prepaid, to WARRANTY SERVICES, CLUB CAR, LLC, 4125 Washington Road, Evans, Georgia 30809, U.S.A., 706-863-3000.

EMISSION CONTROL INFORMATION

Fuel Information

THIS VEHICLE IS CERTIFIED TO OPERATE ON UNLEADED REGULAR GRADE GASOLINE ONLY. A minimum of 87 octane of the anti-knock index is recommended. The anti-knock index is posted on service station pumps in the U.S.A.

Emission Control Information

To protect the environment in which we all live, Club Car has incorporated crankcase emission (1) and exhaust emission (2) control systems (EM) in compliance with applicable regulations of the U.S. Environmental Protection Agency and California Air Resources Board.

1. Crankcase Emission Control System

A sealed-type crankcase emission control system is used to eliminate blow-by gases. The blow-by gases are led to the breather chamber through the crankcase. Then, it is led to the air cleaner.

Oil is separated from the gases while passing through the inside of the breather chamber from the crankcase, and then returned back to the bottom of the crankcase.

2. Exhaust Emission Control System

The exhaust emission control system applied to this engine consists of a carburetor and an ignition system having optimum ignition timing characteristics.

The carburetors have been calibrated to provide lean air/fuel mixture characteristics and optimum fuel economy with a suitable air cleaner and exhaust system.

Maintenance and Warranty

Proper maintenance is necessary to ensure that your engine will continue to have low emission levels. Those items identified by the Periodic Maintenance Chart are necessary to ensure compliance with the applicable standards.

The Club Car Limited Emission Control System Warranty requires that you return your engine to an authorized Club Car Dealer for remedy under warranty. Please read the warranty carefully, and keep it valid by complying with the owner's obligations it contains.

Tampering with Emission Control System Prohibited

California State law prohibits the following

acts or the causing thereof: (1) the removal or rendering inoperative by any person other than for purposes of maintenance, repair, or replacement, of any device or element of design incorporated into any new engine for the purposes of emission control prior to its sale or delivery to the ultimate purchaser or while it is in use, or (2) the use of the engine after such device or element of design has been removed or rendered inoperative by any person.

Among those acts presumed to constitute tampering are the acts listed below:

Do not tamper with the original emission related parts:

- Carburetor and internal parts
- Spark plugs
- Magneto or electronic ignition system
- Fuel filter element
- Air cleaner element
- Crankcase
- Cylinder head
- Breather chamber and internal parts
- Intake pipe and tube

FUEL AND OIL RECOMMENDATIONS

Fuel

Use only clean, fresh, unleaded regular grade gasoline.

Octane Rating

The octane rating of a gasoline is a measure of its resistance to "knocking". Use of a minimum of 87 octane of the anti-knock index is recommended. The anti-knock index is posted on service station pumps in the U.S.A.

NOTE

- If "knocking or pinging" occurs, use a different brand of gasoline or higher octane rating.

CAUTION

- Do not mix oil with gasoline.

Oxygenated Fuel

If you use oxygenated fuel (either ethanol or MTBE added to gasoline), be sure it is unleaded and meets the minimum octane rating requirement.

The following are the EPA approved percentages of fuel oxygenates.

ETHANOL: (Ethyl or Grain Alcohol) You may use gasoline containing up to 10% ethanol by volume.

MTBE: (Methyl Tertiary Butyl Ether) You may use gasoline containing up to 15% MTBE by volume.

METHANOL: (Methanol or Wood Alcohol) 5% by volume.

You may use gasoline containing up to 5% methanol by volume, as long as it also contains cosolvents and corrosion inhibitors to protect the fuel system. Gasoline containing more than 5% methanol by volume may cause starting and/or performance problems. It may also damage metal, rubber, and plastic parts of your fuel system.

WARNING

- Gasoline is extremely flammable and can be explosive under certain conditions. Turn the engine switch OFF. Do not smoke. Make sure the area is well ventilated and free from any source of flame or sparks; this includes any appliance with a pilot light. Never fill the tank so the fuel level rises into the filler neck. If the tank is overfilled, heat may cause the fuel to expand and overflow through the vent in the fuel tank.

Engine Oil

The following engine oils are recommended. API Service Classification: SC, SD, SE, SF, SG, or SH.

WARNING

- After refueling, make sure the tank cap is closed securely.
- If gasoline is spilled on the fuel tank wipe it off immediately.

Oil Viscosity

Choose the viscosity according to the temperature as follows:

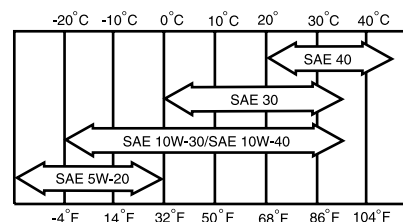

NOTE

- Using multi-grade oils (5W-20, 10W-30, and 10W-40) will increase oil consumption. Check oil level more frequently when using them.

EC DECLARATION OF CONFORMITY

When properly configured, the vehicle complies with the listed Directives.

EC DECLARATION OF CONFORMITY – ELECTRIC VEHICLES		
	DESCRIPTION OF MACHINERY	SERIAL NUMBER PREFIX
	DS Electric Golf Cars	AQ
	Carryall Electric Utility Vehicles	XM, FD, QB, JL, JR
	Precedent Electric Golf Cars	PV, PU, PH, PD
	Precedent Electric Utility Vehicles	PJ
	Transporter Electric Utility Vehicles	JS, JP
	Turf Electric Utility Vehicles	HD, QT, JK
	Villager Electric Utility Vehicles	QS, QE
	XRT Electric Utility Vehicles	JM
Complies with Directive:		
2006/42/EC Machinery	2006/66/EC Battery	2004/108/EC Electromagnetic Compatibility Standards Used for Verification: EN 61000-6-2, EN 61000-6-4
Manufacturer:		
Club Car, LLC 4125 Washington Road Evans, Georgia 30809 USA	Club Car Ingersoll Rand Alma Court Building, Lenneke Marelaan 6 B-1932 Sint-Stevens-Woluwe, Belgium	

EC DECLARATION OF CONFORMITY – GASOLINE AND DIESEL VEHICLES		
	DESCRIPTION OF MACHINERY	SERIAL NUMBER PREFIX
	DS Gas Golf Cars	AG
	Carryall Gas Utility Vehicles	XL, ZG, AF, FG, PG, EG, QG, JU
	Carryall Diesel Utility Vehicles	SD, RF
	Precedent Gas Golf Cars	CF, PR
	Precedent Gas Utility Vehicles	PF
	Transporter Gas Utility Vehicles	JT, JQ
	Turf Gas Utility Vehicles	HG, RG, XG, SG, JV
	Villager Gas Utility Vehicles	KG, MG
Complies with Directive:		
2006/42/EC Machinery	2006/66/EC Battery	
Manufacturer:		
Club Car, LLC 4125 Washington Road Evans, Georgia 30809 USA	Club Car Ingersoll Rand Alma Court Building, Lenneke Marelaan 6 B-1932 Sint-Stevens-Woluwe, Belgium	



Declaration of Conformity

Model Code	Model Number	Model Name
PH	103399101	Precedent i2 Excel
PD	103399201	Precedent i2L Excel
PJ	103399301	Precedent i2 4 Passenger Excel
PU	103399501	Precedent i2 Signature
PV	103399601	Precedent i2 4 Passenger Signature

Serial numbers 1101000001 and greater

Four wheel electric vehicles in the above series which bear the CE mark fulfill all the relevant provisions of the following Directives

Enspricht den Bestimmungen, Conforme Aux Directives, Conforme Con Las Directivas, Voldoet aan Richtlijnen, De Acordo com Directiva, Conforme Alla Direttiva, Opfylder folgende direktiver, Upplyller foljande direktiv

2006/42/EC Machinery
 2006/66/EC Batteries and Accumulators and Waste Batteries and Accumulators
 2004/108/EC Electromagnetic Compatibility

Standards used for verification

Standards für Überprüfung, Standard Utilisee pour Verification, Normas Usado por Comprobacion, Waarden Aangewend voor Verificatie, Modelos Utilizado para Verificacao, Standard per la Verifica, Standarder Anvendte Nemlig Efterprovning, Standarden Anvand for Bekraftanden

EN 61000-6-2
 EN 61000-6-4

Manufacturer

Hersteller, Fabricant, Fabricante, Fabrikant, Fabricante, Fabbicante, Producent, Tillverkare

Club Car, LLC
 4125 Washington Road
 Evans, Georgia 30809
 USA

Authorized representative and person authorized to compile the technical file

Autorisierter Händler, Representant Dument Acrédié, Representante Autorizado, Wettige Vertegenwoordiging, Representate Autorizado, Rappresentante Autorizzato, Autoriscret repræsentant, Auktoriserad representant:

Club Car Ingersoll Rand
 Alma Court Building
 Lenneke Marelaan 6
 B-1932 Sint-Stevens-Woluwe, Belgium

Geoff Stewart
 Lead Engineer, Product Safety

August 2, 2010
 Evans, Georgia, USA

Registered ISO 9001-2008



Declaration of Conformity

Model Code	Model Number	Model Name
PR	102537101	Precedent i2 Gas
CF	102537201	Precedent i2L Gas
PF	102537401	Precedent i2 4 Passenger Gas
PY	103228901	Precedent i2 Signature Gas
PX	103229101	Precedent i2 4 Passenger Signature

Serial numbers 110100001 and greater

Four-wheel gasoline vehicles in the above series that bear the CE mark fulfill all the relevant provisions of the following Directives

Enspricht den Bestimmungen, Conforme Aux Directives, Conforme Con Las Directivas, Voldoet aan Richtlijnen, De Acordo com Directiva, Conforme Alla Direttiva, Opfylder folgende direktiver, Upplyller foljande direktiv

2006/42/EC Machinery

2006/66/EC Batteries and Accumulators and Waste Batteries and Accumulators

Standards used for verification

Standards fur Uberprufung, Standard Utilisee pour Verification, Normas Usado por Comprobacion, Waarden Aangewend voor Verificatie, Modelos Utilizado para Verificacao, Standard per la Verifica, Standarder Anvendte Nemlig Efterproving, Standarden Anvand for Bekraftanden

N/A

Manufacturer

Hersteller, Fabricant, Fabricante, Fabrikant, Fabricante, Fabbicante, Producent, Tillverkare

Club Car, LLC
4125 Washington Road
Evans, Georgia 30809
USA

Authorized representative and person authorized to compile the technical file

Autorisierter Handler, Representant Dument Acredite, Representante Autorizado, Wettige Vertegenwoordiging, Representate Autorizado, Rappresentante Autorizzato, Autoriscret representant, Auktoriserad representant:

Club Car Ingersoll Rand
Alma Court Building
Lenneke Marelaan 6
B-1932 Sint-Stevens-Woluwe, Belgium

Geoff Stewart
Lead Engineer, Product Safety

November 2, 2010
Evans, Georgia, USA

Publication Part Number 103472529

Edition Code 1108U0411T



Club Car, LLC
P.O. Box 204658
Augusta, GA 30917-4658
USA

Web www.clubcar.com
Phone 1.706.863.3000
1.800.ClubCar
Int'l +1 706.863.3000
Fax 1.706.863.5808